

1940 FORD V-8 TRUCKS



1 TON

1½ TON

2 TON

1940 FORD V-8 TRUCKS

1 TON
1 1/2 TON
2 TON

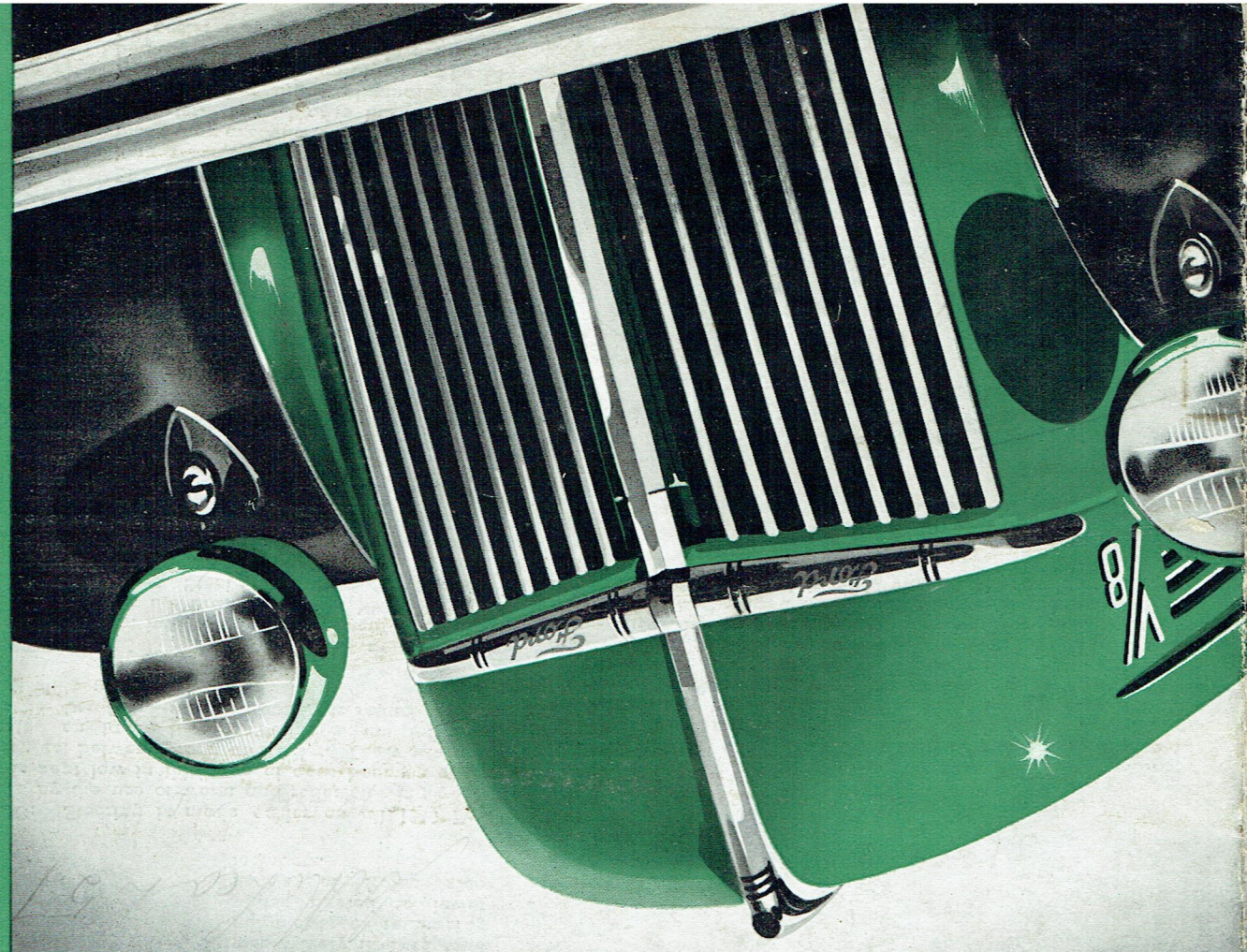

SPECIALISED UNITS FOR MODERN, MEDIUM WEIGHT TRANSPORT built by the World's Largest Truck Manufacturer

Ford V-8 122-in. W.B. truck chassis with closed front end. Available also as chassis, cab chassis, and with complete range of body styles including: platform, dropside, steel straightside, well-type and panel van. Chassis is 6 in. deep with wide flanged alligator-type cross members for extra strength and rigidity.

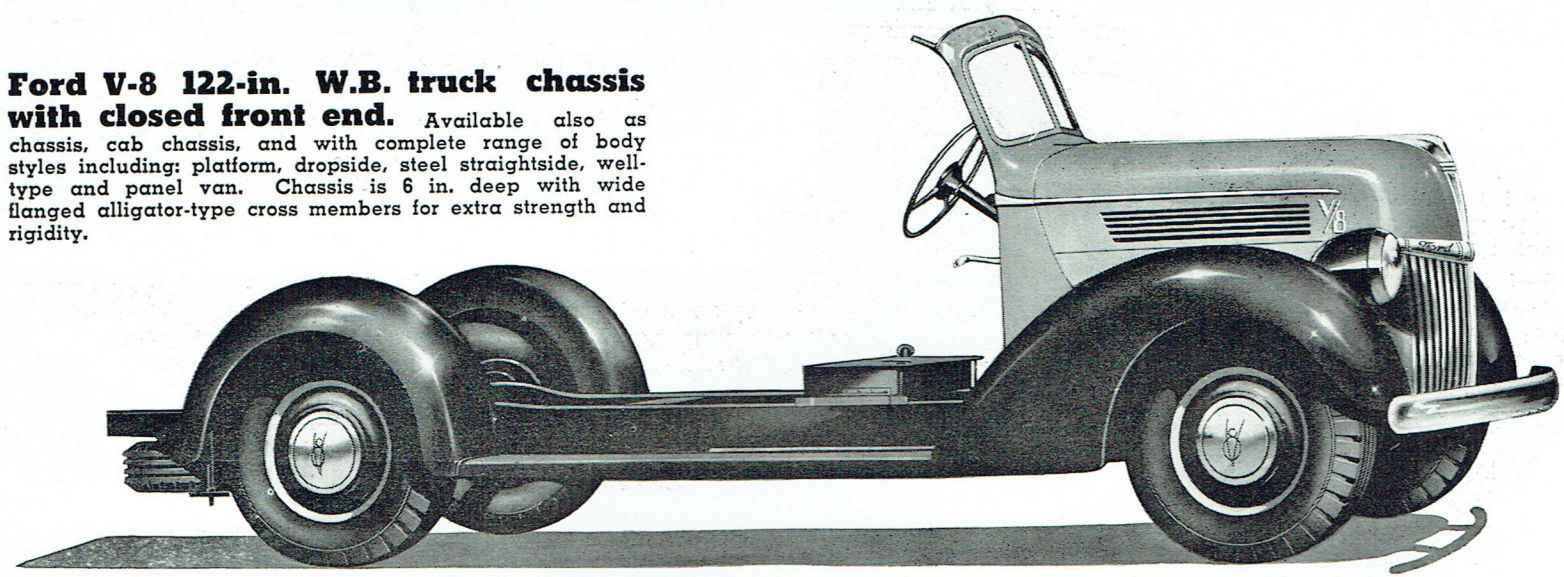

Ford V-8 122-in. W.B. steel straight-side. The ideal general purpose unit, specially suited to farmers and graziers. Roomy all steel body provides ample space for payloads up to 30 cwt. with riding comfort that is exceptional. New luxury features include: "Shiftoguide" speedometer, new pivot ventilating side windows, etc.

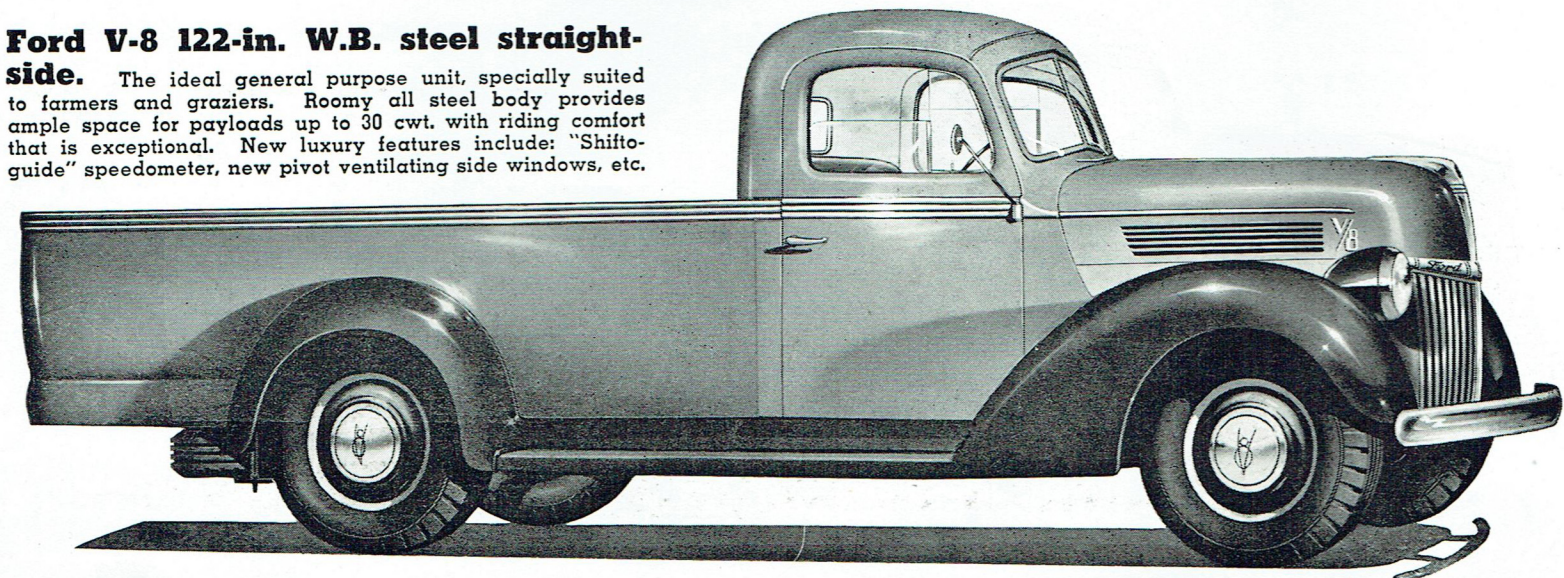

Ford V-8 134-in. W.B. platform body. Also available with dropside body, in 134-in. and 158-in. wheelbases, 30-cwt. or 2-ton capacities. Generous loading space dimensions are as follows: 134-in. W.B., 114 in. x 84 in. x 12 in. 158-in. W.B., 150 in. x 84 in. x 12 in. 2-ton models have dual rear wheels and 30 x 5 8-ply tires as standard equipment.

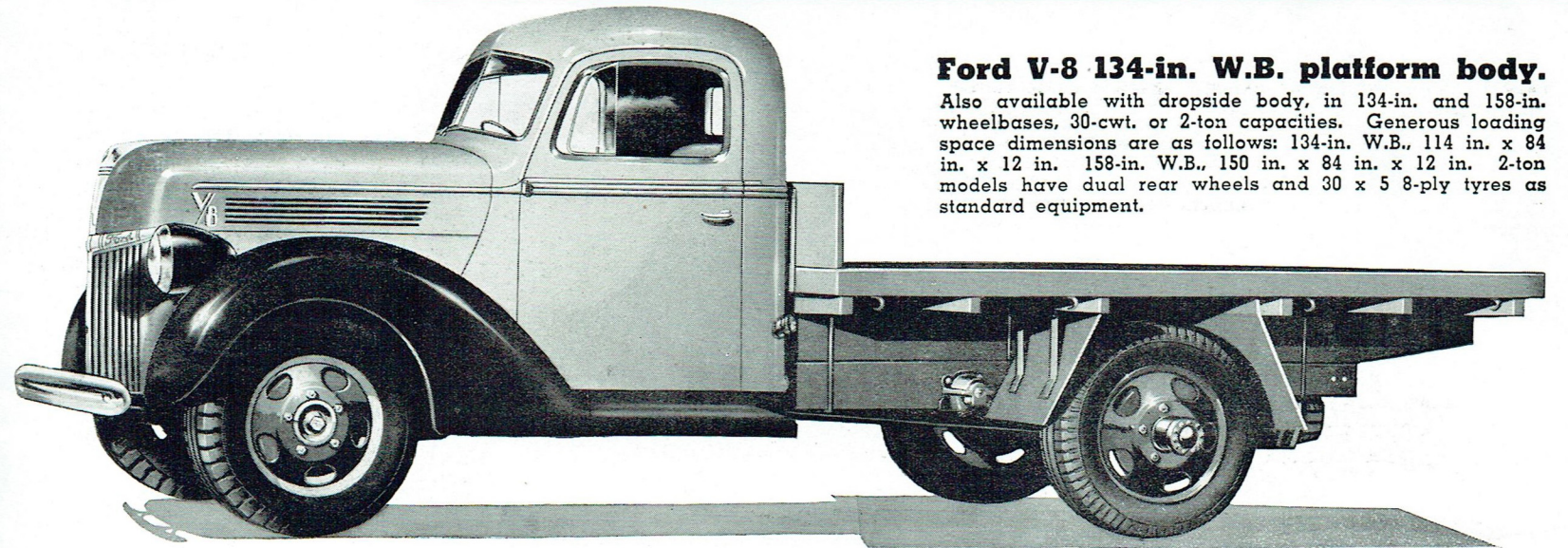

Ford V-8 30-40-cwt. chassis with cab. 134-in. and 158-in. wheelbases, also available as chassis, and chassis with closed front end. New quality features include: rugged frames with new wide flanged alligator-type cross members. New cushioned drive line and new semi-elliptic front springs.

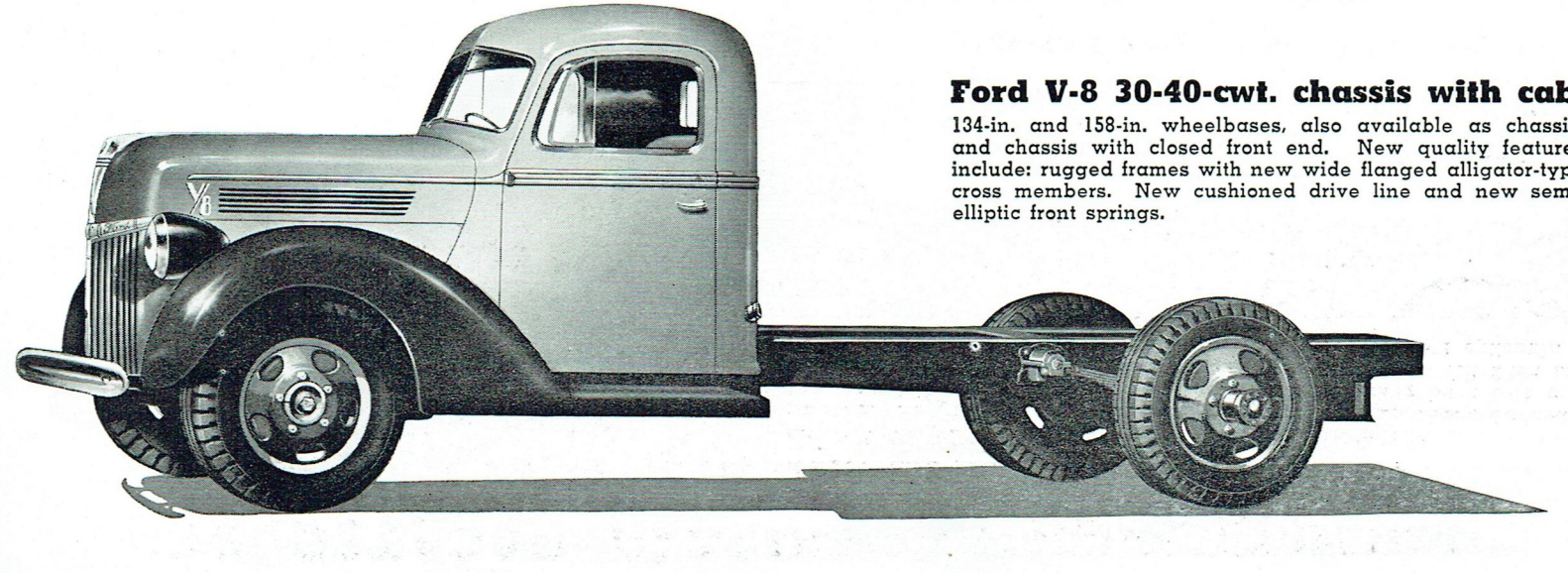

WHEELS—1-Ton: 5 17" x 5", 30-cwt. 2 17" x 5" and 3 17" x 6". Full truck type, steel disc riveted to steel rim.

TYRES—1-Ton: front 17 x 7.00 8-ply, rear 17 x 7.00 8-ply. 30-cwt.: front 17 x 7.00 8-ply, rear 17 x 7.50 8-ply.

TURNING RADIUS—22 ft.

134-IN. AND 158-IN. W.B. 30-40-CWT. TRUCKS.

CLUTCH—Heavy-duty semi-centrifugal. Plate pressure increased by centrifugal force as engine speed is increased. Cushioned hub with vibration damper. Diameter, 11 in.; total friction area, 123.7 sq. in.

TRANSMISSION—Heavy duty type, 4 forward speeds. Roller and ball bearings in all forward speeds. S.A.E. standard 8-bolt power take-off opening in side of gear box.

UNIVERSAL JOINTS—Needle roller bearing type, fully enclosed and permanently sealed against dust and mud. Centre unit is rubber mounted for greater anti-friction efficiency, smoother operation.

FRAME—High carbon frame steel with deep section wide-flanged alligator-type cross members. Side member dimensions: Depth, 7 in.; width, 2 1/2 in.; thickness, 3/8 in. Elastic limit, 42,000 lbs. per sq. in.

AXLES—Front: Carbon Mangnese steel, drop centre type, large and heavy section. Rear: Full floating with straddle mounted pinion and beam section. Hubs: 134-in. W.B. 30-cwt., 5.83 to 1.18-in. W.B., 30-40-cwt. and 2-ton, 6.66 to 1 (5.83 to 1 optional).

SPRINGS—Semi-elliptic front and rear. Oil-less bearing type shackles with spring eyes double-wrapped for safety. Total spring capacities: 30-cwt. 10,050 lbs., 2-ton 11,650 lbs.

STEERING—Worm and roller type, ratio 18.4 to 1. Steering wheel diameter 18 in.

BRAKES—Powerful hydraulic, with entirely independent hand-brake system operating on drive shaft. Total braking area, 365 sq. in. Drum rings are cast iron, with steel drum discs.

WHEELS—Tapered steel disc riveted to steel rim, 134-in. W.B. 30-cwt., 5 20 in. x 5 in.; 2-ton, 7 20 in. x 5 in. 158-in. W.B. 30-40-cwt., 2 20 in. x 5 in. front, 2 20 in. x 6 in. rear and spare, 2-ton, 2 20 in. x 5 in.

TYRES—134-in. W.B. 30-cwt.: front, 2 30 x 5 8-ply; rear, 2 32 x 6 8-ply. 2-ton: 6 30 x 5 8-ply. 158-in. W.B. 30-40-cwt.: 2 32 x 6 8-ply. front, 2 32 x 6 10-ply rear, 2-ton: 6 30 x 5 8-ply.

FORD MOTOR COMPANY OF AUSTRALIA PTY. LTD. (INCORPORATED IN VICTORIA), REGISTERED OFFICE: GEELONG, DM669-25M-40.

Ford Motor Company of Australia Pty. Ltd., whose policy is one of continuous improvement, reserves the right to change specifications and prices at any time without notice or incurring liability to purchasers.

ENGINE.
ENGINE—Bore, 3.062 in. Stroke, 3.75 in. Piston displacement, 221 cub. in. Engine torque, 177 ft. lbs. at 2,500 r.p.m. ENGINE BLOCK—Steel casting. Cast alloy steel, weight 66 lbs. 3 main bearings, effective main bearing full length water jackets, polished mirror finish cylinders. CRANKSHAFT—Piston, CAMSHAFT—Water-resisting cast alloy iron. Three steel-backed cast alloy bearings, floating type pins with bearing surfaces in both rod and crank. FLOTTING TYPE PINS WITH BEARING SURFACES IN BOTH ROD AND CRANK. VALVE SEAT INSERTS—Tungsten steel for all intake and exhaust valves. LUBRICATION—Direct pressure oiling to all crankshaft, connecting rod bearings; also to timing gears, fan COOLING—Two centrifugal water pumps, self-lubricating type. Fan is now mounted on end of crankshaft for greater efficiency. FUEL SYSTEM—Dual down draft carburetor fitted with air cleaner and silencer. Ignition—Distributor with distributor and coil in water-proof housing. Full automatic spark advance—vacuum-controlled governor. BATTERY—17 plate—100 ampere hour capacity.

122-IN. W.B. 1-TON and 30-CWT. TRUCKS.
CLUTCH—Semi-centrifugal type. Plate pressure increases as engine speed is increased. 11 in. diameter, friction area 123.7 sq. in.

TRANSMISSION—1-Ton, 4-speed; 30-cwt., 4-speed. Heavy-duty type with roller and ball bearings in all forward speeds.

UNIVERSAL JOINTS—Needle roller bearing type, fully enclosed and permanently sealed against dust and mud.

FRAME—High carbon pressed steel, 6 cross members, alligator type, of deep section and widely flanged. Length 189.56 in., depth 6 in., width 2 1/2 in., thickness 3/8 in.

AXLES—Front: Heat-treated alloy, drop centre type, large I beam section. Rear: Full-floating with straddle-mounted pinion and ring gear thrust plate, ratio of 4.857 to 1.

SPRINGS—Semi-elliptic front and rear. Oil-less bearing type shackles with spring eyes double-wrapped for safety. Total spring capacities—1-Ton 8,800 lbs.; 30-cwt., 8,000 lbs.

SHOCK ABSORBERS—Double-acting aero-type hydraulic on front.

STEERING—Worm and roller type, ratio 18.2 to 1. Steering wheel 17 in. diameter.

BRAKES—Powerful hydraulic. Rear drums are 14 in. diameter, 2 in. wide. Drum rings are cast iron, cast integrally with steel drum discs. Total lining area, 185.8 sq. in. Handbrake operates rear wheel brakes independently.

FORD V-8 is engineered for GREATER ECONOMY IN ITS PAYLOAD CLASS

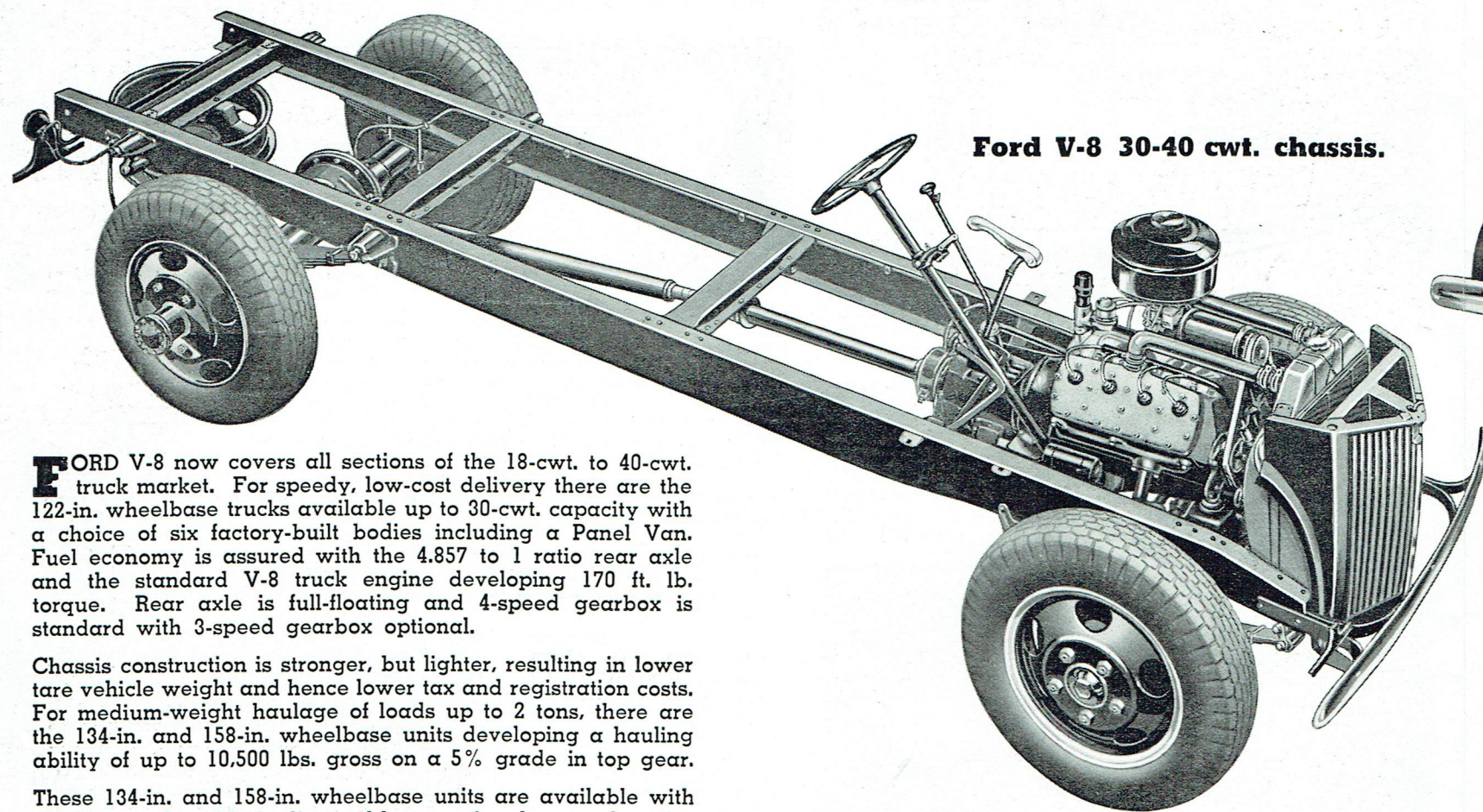

Ford V-8 30-40 cwt. chassis.

FORD V-8 now covers all sections of the 18-cwt. to 40-cwt. truck market. For speedy, low-cost delivery there are the 122-in. wheelbase trucks available up to 30-cwt. capacity with a choice of six factory-built bodies including a Panel Van. Fuel economy is assured with the 4.857 to 1 ratio rear axle and the standard V-8 truck engine developing 170 ft. lb. torque. Rear axle is full-floating and 4-speed gearbox is standard with 3-speed gearbox optional.

Chassis construction is stronger, but lighter, resulting in lower tare vehicle weight and hence lower tax and registration costs. For medium-weight haulage of loads up to 2 tons, there are the 134-in. and 158-in. wheelbase units developing a hauling ability of up to 10,500 lbs. gross on a 5% grade in top gear.

These 134-in. and 158-in. wheelbase units are available with platform or dropside bodies and have optional rear axle ratios of 5.83 to 1 or 6.66 to 1 to care for varying haulage requirements. All Ford V-8 Trucks in the 1-ton to 2-ton range are available as chassis and cab-chassis for the fitment of special bodies. We suggest that you ask your dealer to place the V-8

unit suited to your requirements at your disposal to test over your own routes with your own loads and driver. An "on-the-job" test is the most convincing proof of the superior haulage ability and in-built economy of these grand, new trucks.

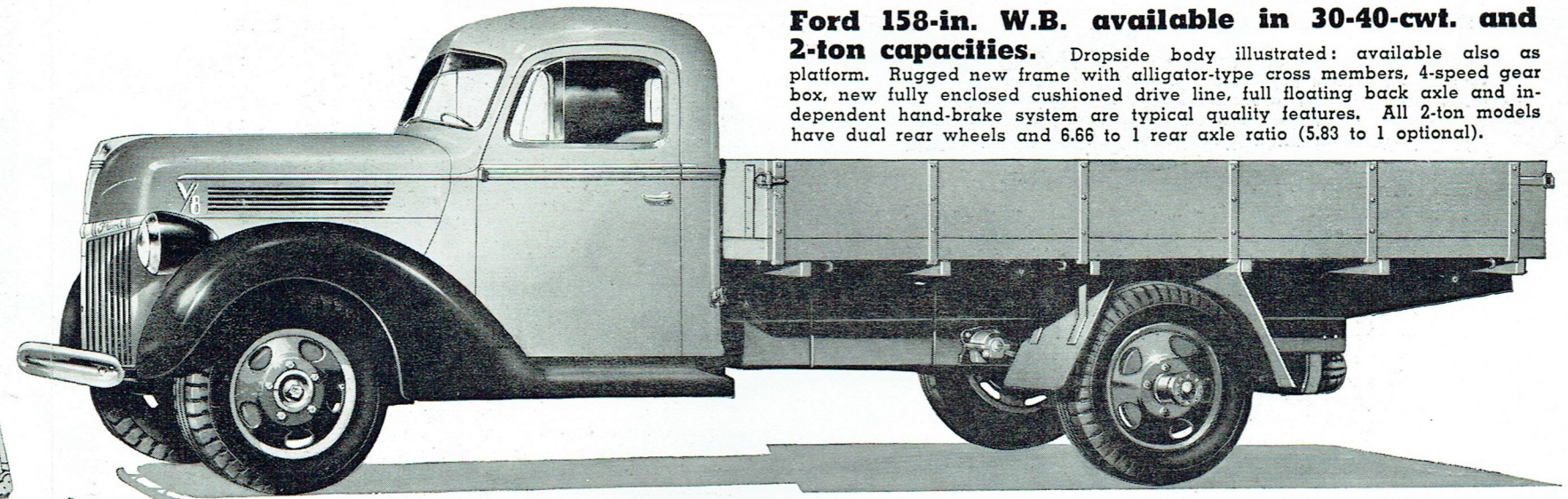

Ford 158-in. W.B. available in 30-40-cwt. and 2-ton capacities. Dropside body illustrated; available also as platform. Rugged new frame with alligator-type cross members, 4-speed gear box, new fully enclosed cushioned drive line, full floating back axle and independent hand-brake system are typical quality features. All 2-ton models have dual rear wheels and 6.66 to 1 rear axle ratio (5.83 to 1 optional).

Ford 122-in. W.B. Van. 1-ton or 30-cwt. capacities. Already a leader in its class for performance and economy, the smart lines and shapely body styling of this 1940 122-in. W.B. Van will make it a leader in style value too. With attractive sign-writing display this unit makes a striking advertising and selling display for any business.

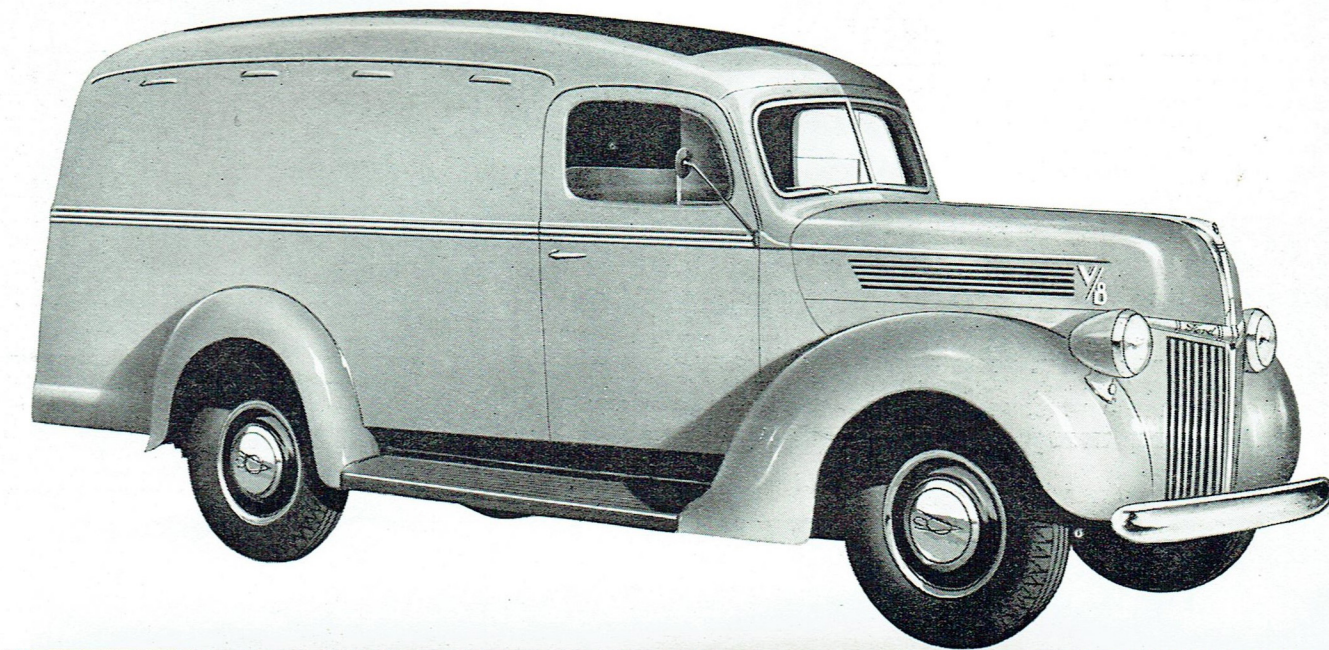

QUALITY FEATURES OF THESE 1 and 2-TON TRUCKS that mean RELIABILITY ON THE JOB

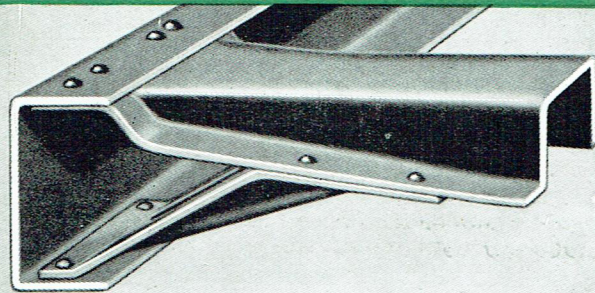

NEW RUGGED FRAME: Frame construction is exceptionally rugged. Deep side member channels have wide flanges. Sturdy cross members are also widely flanged with alligator-type reinforcing plates riveted to lower flange of frame side members.

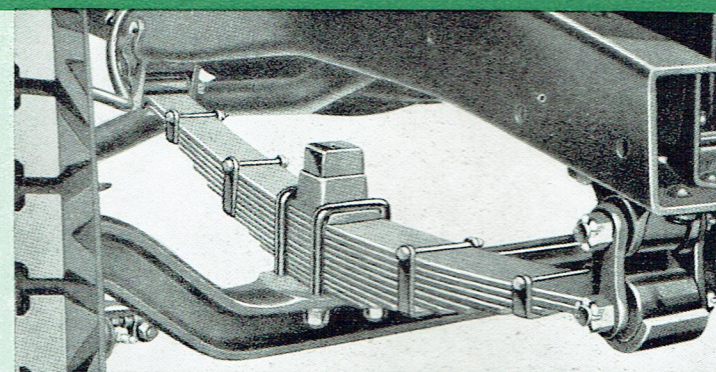

NEW SPRINGS: New long front semi-elliptic springs make the 30-40-cwt. truck ride easier. Shackle bushings are steel-backed, self-lubricating type making lubrication unnecessary. Spring leaves are of chrome alloy steel.

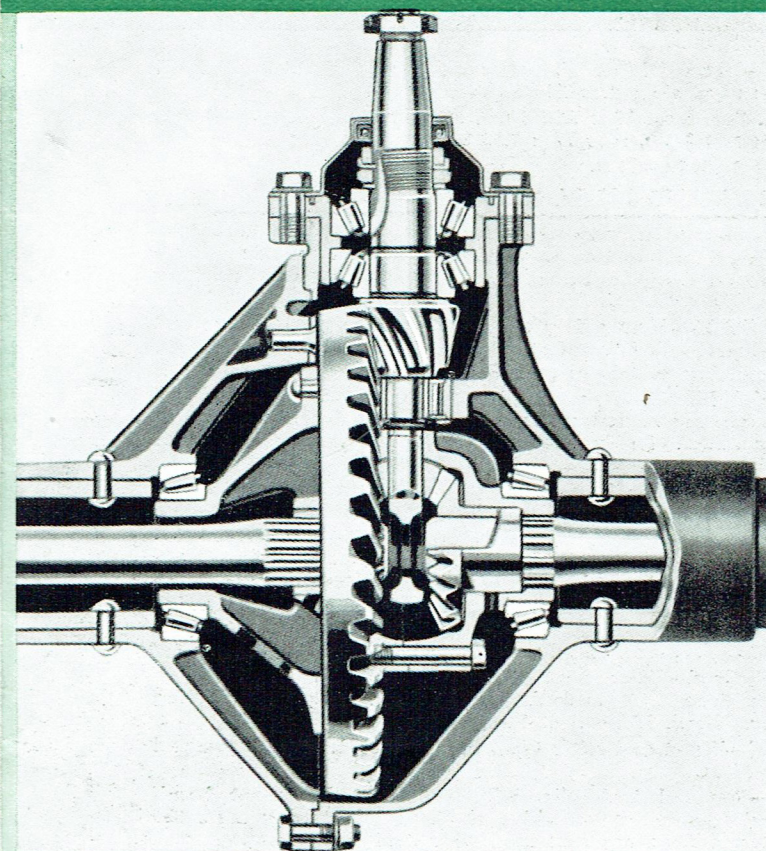

FULL FLOATING REAR AXLE: Ford V-8 rear axles are noted for their exceptional reliability achieved through rugged design and quality materials. The pinion is mounted on two large tapered roller bearings with another roller bearing at back to prevent it springing away from the ring gear when unduly stressed. A bronze thrust plate opposite the pinion prevents ring gear from springing. With friction minimized Ford axles have extremely high power transmitting efficiency.

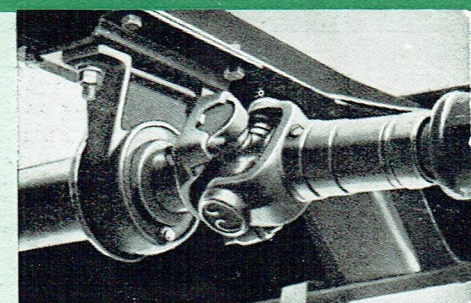

NEW UNIVERSAL JOINTS: The new drive line centre bearing is completely encased in rubber for greater anti-friction efficiency, to insulate chassis against tyre and drive line noises, and to maintain better alignment. Needle roller bearings are fully enclosed and dust-proof for long life.

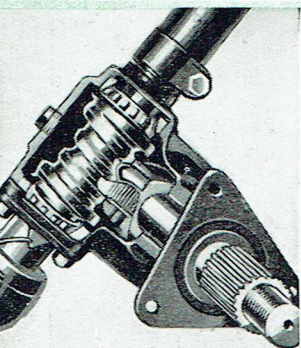

STEERING: Steering is made easier on all 1940 Ford V-8 trucks by the use of worm and roller steering gears. Friction is kept low in this type of gear because of the rolling contact between worm and roller. The worm gear is mounted on tapered roller bearings, the roller on needle roller bearings—all contributing to reduce friction to the absolute minimum.

COMPOSITE BRAKE DRUMS: The brake drum ring is cast iron and is cast integrally with the steel drum disc. Cast iron is used for the braking surface because of its high resistance to wear. Steel for the drum disc provides high strength, low weight. Brakes are big powerful hydraulics, with an entirely independent mechanical handbrake operating directly on the drive-shaft.

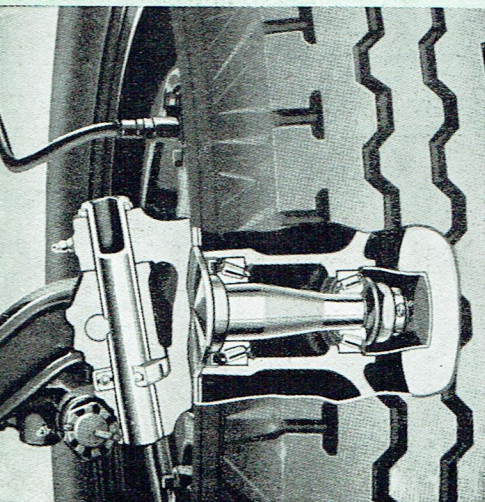

BIG KING PINS: For extra strength, long wear and hard service, the king pins are exceptionally large—1½ in. diameter. Long bronze bushings with large bearing areas eliminate wear. Note the special anti-friction thrust bearing used in the king pin mounting for easier steering, maximum life.

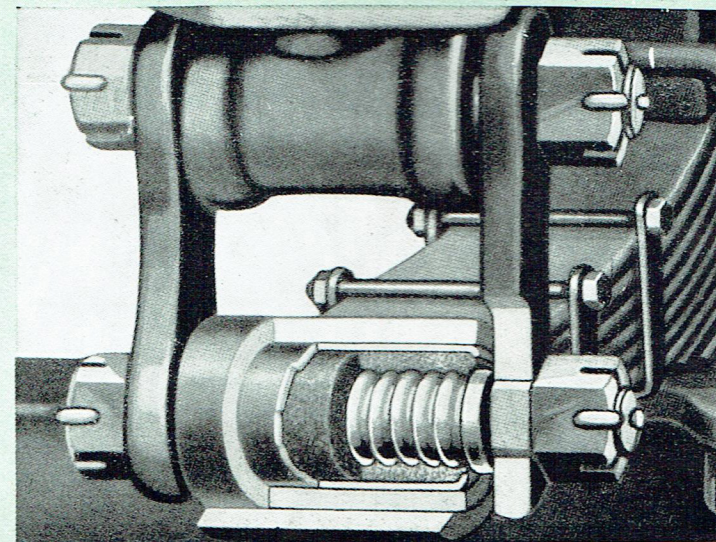

SPRING SHACKLES: Steel casing is a tight press fit in the spring eye. Space between casing and radially grooved stud is filled with highly compressed non-metallic material impregnated with lubricant. Additional lubricant is unnecessary; maintenance costs are cut.

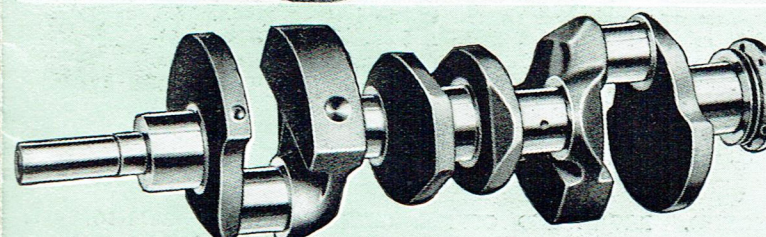

CAST ALLOY STEEL CRANKSHAFT: Crankshafts are of special cast alloy steel developed by Ford metallurgists. Smoothness of bearing surface is measured in millionths of an inch. Balance is accurate within .2 of an ounce-inch.

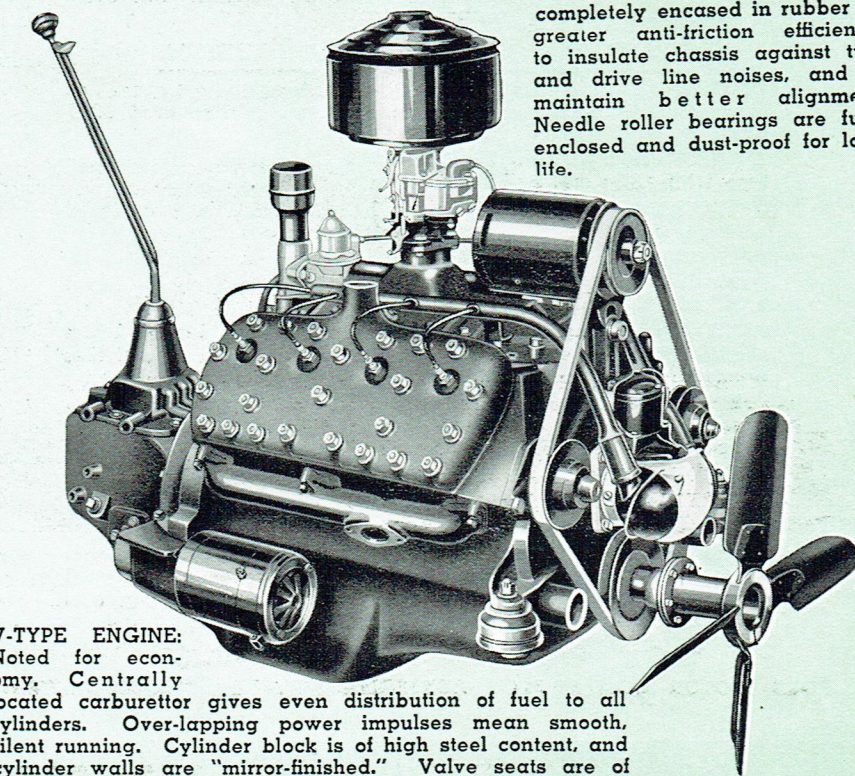

V-TYPE ENGINE: Noted for economy. Centrally located carburettor gives even distribution of fuel to all cylinders. Over-lapping power impulses mean smooth, silent running. Cylinder block is of high steel content, and cylinder walls are "mirror-finished." Valve seats are of special tungsten steel for both inlet and exhaust valves.

SPECIFICATIONS

ENGINE.

ENGINE—Bore, 3.062 in. Stroke, 3.75 in. Piston displacement, 221 cub. in. Engine Torque, 170 ft. lbs. at 2,200 r.p.m. **ENGINE BLOCK**—Semi-steel casting, full length water jackets, polished mirror finish cylinders. **CRANKSHAFT**—Cast alloy steel, weight 66 lbs. 3 main bearings, effective main bearing surface 36.99 sq. in. **CONNECTING RODS**—Manganese steel forgings, floating type alloy bearings, bronze piston pin bushings. **PISTONS**—Light-weight cast alloy. Floating type piston pins with bearing surfaces in both rod and piston. **CAMSHAFT**—Wear-resisting cast alloy iron. Three steel-backed babbitt bearings. **VALVES**—All intake and exhaust valves are heat-resisting chrome nickel alloy steel. **VALVE SEAT INSERTS**—Tungsten steel for all intake and exhaust valves. **LUBRICATION**—Direct pressure oiling to all crankshaft, camshaft and connecting rod bearings; also to timing gears. **COOLING**—Two centrifugal water pumps, packless, self-lubricating type. Fan is now mounted on end of crankshaft for greater efficiency. **FUEL SYSTEM**—Dual down-draught carburettor fitted with oil bath air cleaner and silencer. **IGNITION**—Direct driven unit with distributor and coil in waterproof housing. Fully automatic spark advance—vacuum-controlled governor. **BATTERY**—17 plate—100 ampere hour capacity.

122-IN. W.B. 1-TON and 30-cwt. TRUCKS.

CLUTCH—Semi-centrifugal type. Plate pressure increases as engine speed is increased. 11 in. diameter, friction area 123.7 sq. in.

TRANSMISSION—1-Ton, 3-speed; 30-cwt., 4-speed. Heavy-duty type with roller and ball bearings in all forward speeds.

UNIVERSAL JOINTS—Needle roller bearing type, fully enclosed and permanently sealed against dust and mud.

FRAME—High carbon pressed steel. 6 cross members, alligator type, of deep section and widely flanged. Length 189.56 in., depth 6 in., width 2½ in., thickness ⅞ in.

AXLES—Front: Heat-treated alloy, drop centre type, large I beam section. Rear: full-floating with straddle-mounted pinion and ring gear thrust plate, ratio of 4.857 to 1.

SPRINGS—Semi-elliptic front and rear. Oil-less bearing type shackles with spring eyes double-wrapped for safety. Total spring capacities—1-Ton: 6,800 lbs.; 30-cwt.: 8,000 lbs.

SHOCK ABSORBERS—Double-acting aero-type hydraulic on front.

STEERING—Worm and roller type, ratio 18.2 to 1. Steering wheel 17 in. diameter.

BRAKES—Powerful hydraulic. Rear drums are 14 in. diameter, 2 in. wide. Drum rings are cast iron, cast integrally with steel drum discs. Total lining area 185.8 sq. in. Handbrake operates rear wheel brakes independently.

WHEELS—1-Ton: 5 17" x 5". 30-cwt.: 2 17" x 5" and 3 17" x 6". Full truck type, steel disc riveted to steel rim.

TYRES—1-Ton: front 17 x 7.00 6-ply, rear 17 x 7.00 8-ply. 30-cwt.: front 17 x 7.00 8-ply, rear 17 x 7.50 8-ply.

TURNING RADIUS—22 ft.

134-IN. AND 158-IN. W.B. 30-40-CWT. TRUCKS.

CLUTCH—Heavy-duty semi-centrifugal. Plate pressure increased by centrifugal force as engine speed is increased. Cushioned hub with vibration damper. Diameter, 11 in.; total friction area, 123.7 sq. in.

TRANSMISSION—Heavy duty type, 4 forward speeds. Roller and ball bearings in all forward speeds. S.A.E. standard 6-bolt power take-off opening in side of gear box.

UNIVERSAL JOINTS—Needle roller bearing type, fully enclosed and permanently sealed against dust and mud. Centre unit is rubber mounted for greater anti-friction efficiency, smoother operation.

FRAME—High carbon frame steel with deep section wide-flanged alligator-type cross members. Side member dimensions: Depth, 7 in.; width, 2½ in.; thickness, ⅞ in. Elastic limit, 42,000 lbs. per sq. in.

AXLES—Front: Carbon Manganese steel, drop centre type, large "I" beam section. Rear: Full floating with straddle mounted pinion and ring gear thrust plate. Ratios: 134-in. W.B. 30-cwt., 5.83 to 1. 158-in. W.B., 30-40-cwt. and 2-ton, 6.66 to 1 (5.83 to 1 optional).

SPRINGS—Semi-elliptic front and rear. Oil-less bearing type shackles with spring eyes double-wrapped for safety. Total spring capacities: 30-cwt. 10,050 lbs., 2-ton 11,650 lbs.

STEERING—Worm and roller type, ratio 18.4 to 1. Steering wheel diameter 18 in.

BRAKES—Powerful hydraulic, with entirely independent hand-brake system operating on drive shaft. Total braking area, 365 sq. in. Drum rings are cast iron, with steel drum discs.

WHEELS—Tapered steel disc riveted to steel rim. 134-in. W.B. 30-cwt., 5 20 in. x 5 in.; 2-ton, 7 20 in. x 5 in. 158-in. W.B. 30-40-cwt., 2 20 in. x 5 in. front, 2 20 in. x 6 in. rear and spare. 2-ton, 7 20 in. x 5 in.

TYRES—134-in. W.B. 30-cwt.: front, 2 30 x 5 8-ply; rear, 2 32 x 6 8-ply. 2-ton: 6 30 x 5 8-ply. 158-in. W.B. 30-40-cwt.: 2 32 x 6 8-ply front; 2 32 x 6 10-ply rear. 2-ton: 6 30 x 5 8-ply.

FORD MOTOR COMPANY OF AUSTRALIA PTY. LTD. (INCORPORATED IN VICTORIA). REGISTERED OFFICE: GEELONG. DM669-25M-40.