

# *Mechanics Manual*

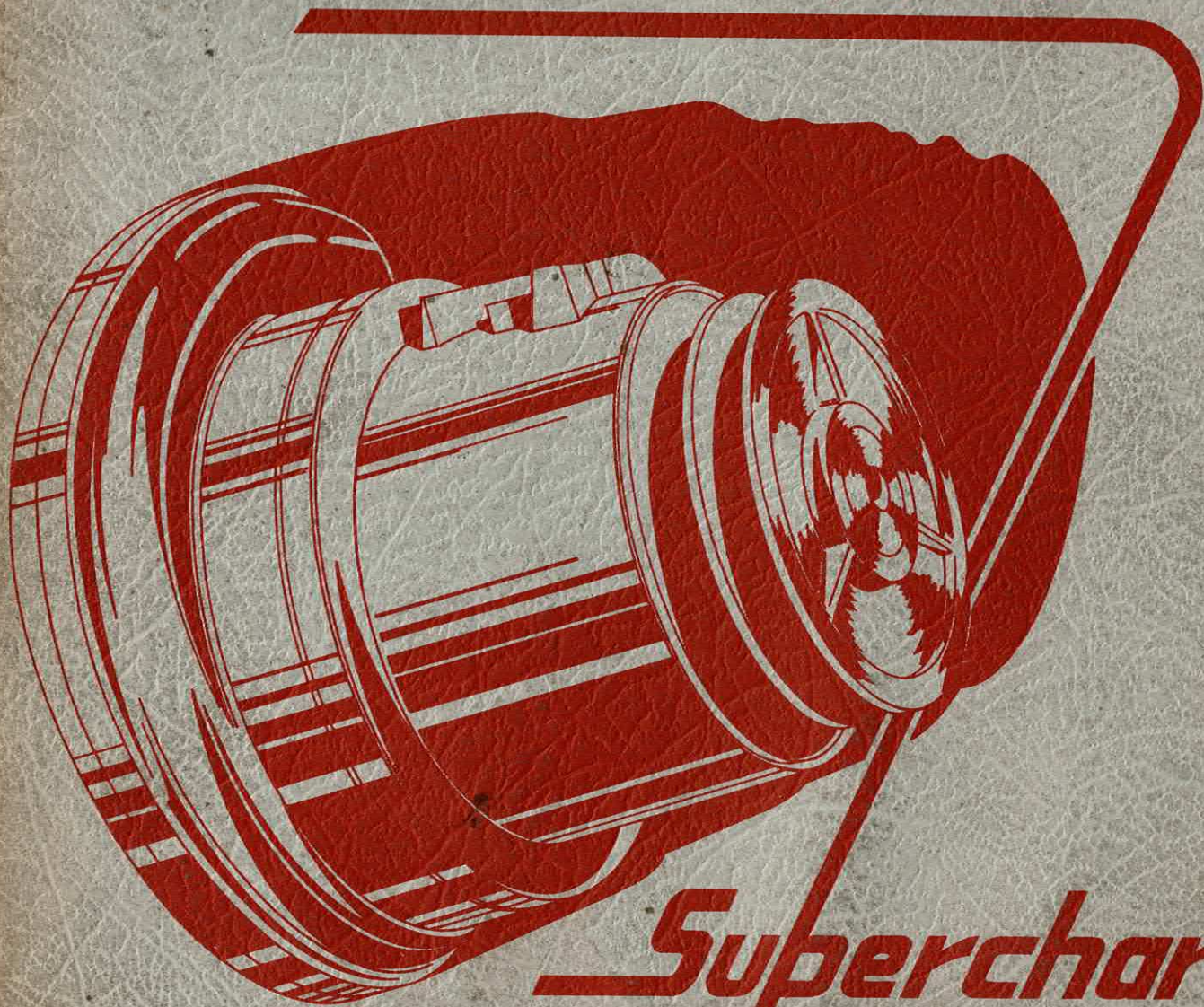

## *Supercharger*

**WILLYS MOTORS, INC.  
KAISER-WILLYS SALES DIVISION  
TOLEDO, OHIO**

## FOREWORD

The Kaiser Supercharger, when correctly installed, adjusted and serviced, had proved itself to be a trouble-free unit with a service life equal to that of the automobile engine. It is a precision built unit, adjusted, tested and installed on the Kaiser 6-226 engine at the factory.

Developed from the aeronautical type supercharger, it delivers a denser fuel-air mixture to the combustion chambers under increased pressure, auto-matically providing a highly volatile charge for increased horsepower.

The unit is completely automatic in operation and trouble-free. As is true with all mechanical units, however, some preventive maintenance is a must and after long use it may be necessary to replace some operating parts.

This manual provides complete information for the service mechanic. All details of preventive maintenance, operation, removal, and installation, disassembly and reassembly, and final adjustment are given in a step by step sequence.

Always refer to the manual when either overhauling or adjusting a supercharger, for some parts must be fitted with extremely close clearances and there are a number of important precautions which must be observed. No unit will provide like-new operation unless assembled to the original factory clearances.

The special tools listed are essential when overhauling a unit. They should be ordered direct from the Miller Manufacturing Company, 5919 Tireman Avenue, Detroit 4, Michigan.

Willys Motors, Inc.  
Toledo, Ohio

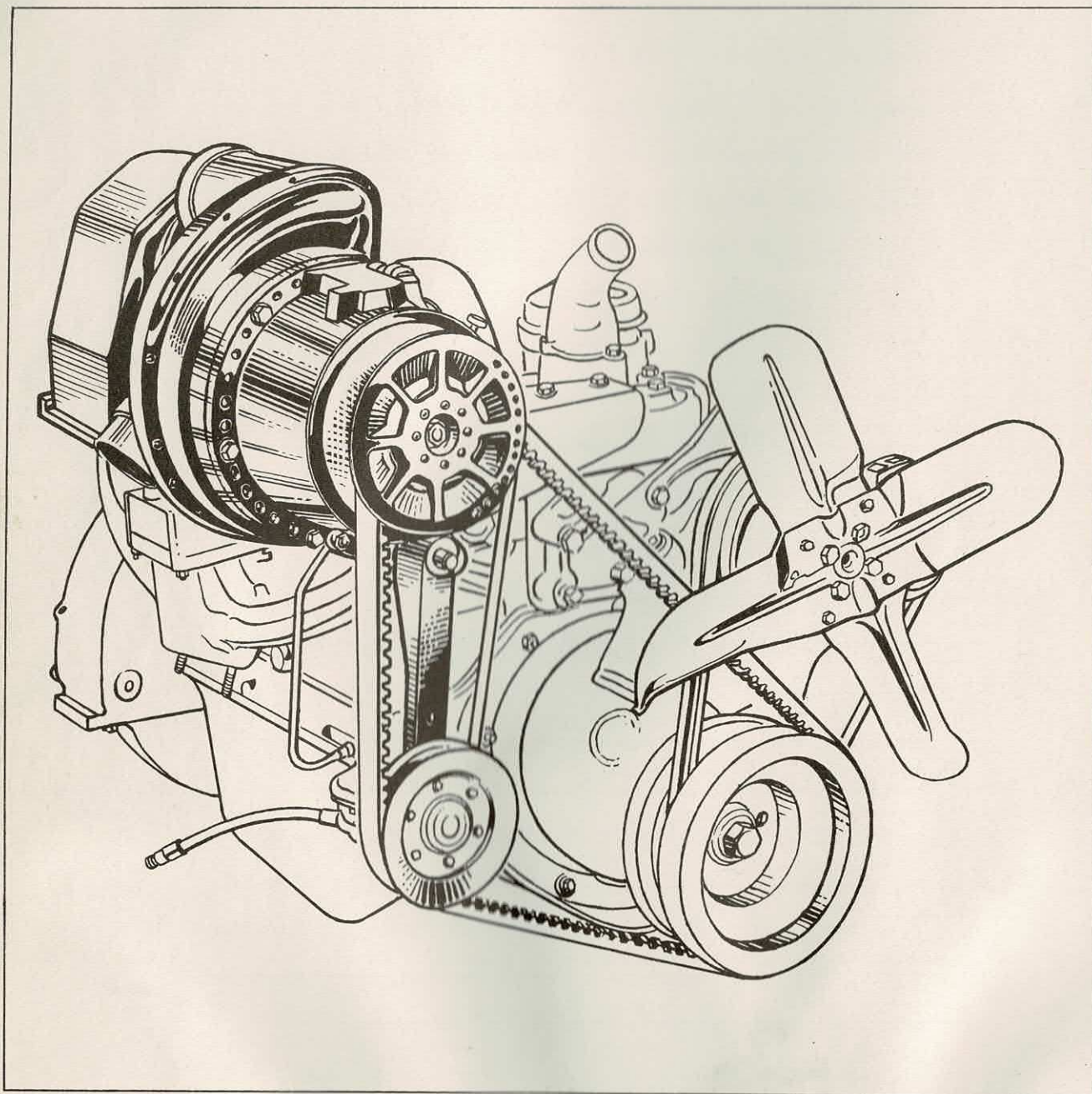

**THE KAISER SUPERCHARGER**

## TABLE OF CONTENTS

	PAGE NO.
<u>Section I      Mechanical Operation</u> .....	<u>4</u>
1. General	
2. Drive System	
3. Function of Component Assemblies	
4. Lubrication System	
5. Control System	
<u>Section II      Removing Supercharger from Engine</u> .....	<u>13</u>
<u>Section III     Disassembly</u> .....	<u>13</u>
1. Removal of Variable-Ratio Pulley	
2. Air Piston and Spring Removal	
3. Disassembly of Bearing and Scroll Housing	
4. Removal of Input and Output Shafts	
5. Disassembly of Input Shaft and Oil Pump	
6. Solenoid Regulator Assembly	
<u>Section IV     Assembly</u> .....	<u>18</u>
1. Introduction	
2. Output Shaft and Planetary System	
3. Assembly of Input Shaft and Oil Pump	
4. Assembly of Bearing Housing to Scroll Housing	
5. Installation of Air Piston and Cover	
6. Installation of Variable - Ratio Pulley	
7. Installation of Impeller	
8. Solenoid Regulator	
9. Belt-Tensioning Arm and Mounting Bracket	
10. Checking	
<u>Section V      Installing Supercharger on Engine</u> .....	<u>22</u>
<u>Section VI     Solenoid Regulator Adjustment</u> .....	<u>23</u>
1. Introduction	
2. Diaphragm Adjustment	
<u>Section VII    Kick-Down Switch Adjustment</u> .....	<u>24</u>

## SECTION I

### MECHANICAL OPERATION

#### 1. General

As with all centrifugal-type superchargers, it is necessary to drive the impeller at a very high RPM speed to obtain the required boost pressure output. This is accomplished in the Kaiser Supercharger by incorporating two points of shaft speed-up in the design. The first is at the variable-ratio pulley, keyed to the input shaft, and the second point is at the planetary drive system between the input and output shafts.

When used with the Kaiser 7-1/2 inch diameter crankshaft pulley, the variable-ratio pulley offers a 1.3 to 1 RPM increase when it is in the fully closed position. When the pulley is fully opened, the increase is 2.3 to 1. Thus, when the flanges are fully closed, the supercharger is operating at "low blower". When the flanges are fully separated, the supercharger is being driven at "high blower".

Movement of the rear, or sliding flange of the pulley is automatically controlled by the functioning of the control system. Operation and function of the control system is explained in Section I, paragraph 5, Control System.

The belt-tensioning arm, and idler pulley, apply pressure against the drive belt and cause the belt to pull down into the pulley and separate the flanges during the shifting cycle from "low" to "high" blower.

The planetary drive system, incorporated between the input and output shafts, is the second point of RPM step-up. The ratio of the system is a constant 1 to 4.44 and does not vary under any operating conditions. When the supercharger is in "low blower", the impeller is turning approximately 5.7 times as fast as the crankshaft (1x1.3x4.44). In "High Blower", the impeller is

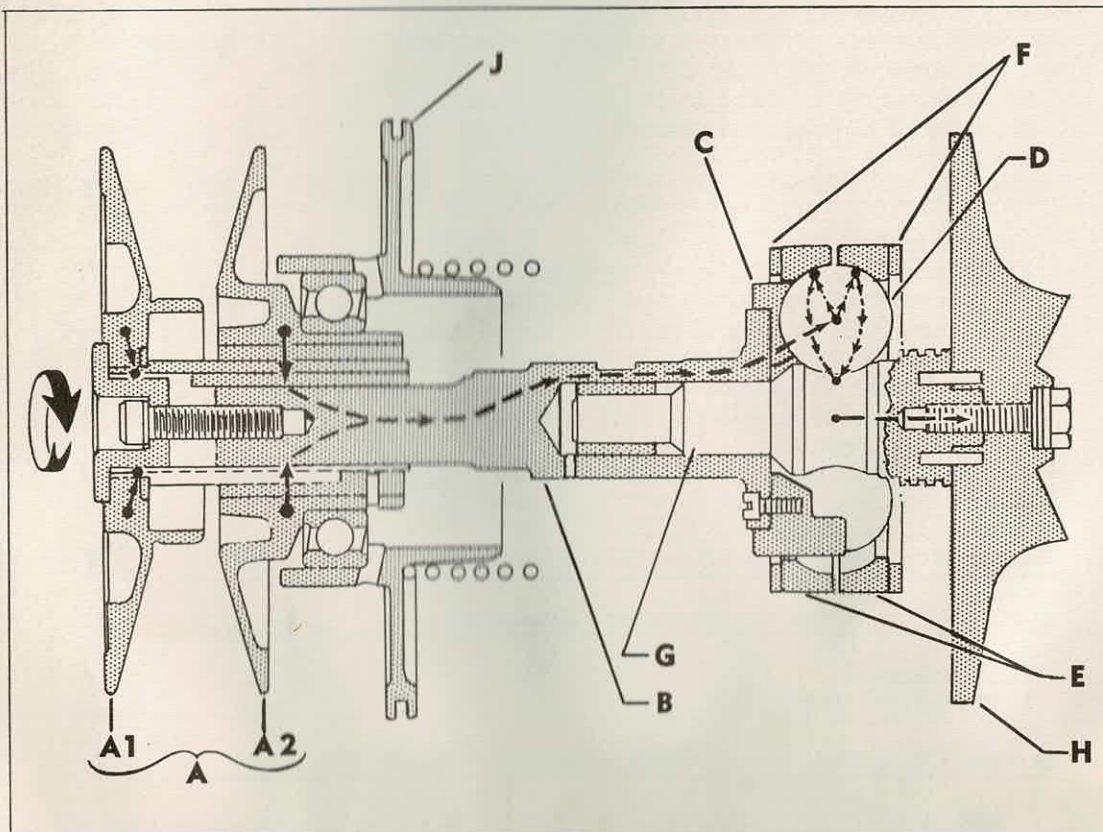

FIG. 1 POWER FLOW THROUGH DRIVE

- |  |                   |
|--|-------------------|
| A—Variable-Ratio Input Pulley Assembly | E—Drive Ball Race |
| A-1—Pulley Fixed Flange                | F—Clutch Disc     |
| A-2—Pulley Sliding Flange              | G—Output Shaft    |
| B—Input Shaft                          | H—Impeller        |
| C—Ball Drive Assembly                  | J—Air Piston      |
| D—Drive Ball                           |                   |

being driven approximately 10 times faster than the crankshaft (1x2.3x4.44). However, when the supercharger is in "high blower" and the engine is turning at high RPM, the regulating action of the control system limits the boost output to a predetermined level.

The control system regulates the boost output of the supercharger by governing the movement of the sliding flange of the variable-ratio pulley. Simply, the control system is a solenoid operated valve that controls the passage of boost pressure, taken from the discharge throat of the supercharger, into an air chamber. Within the air chamber is an air piston which is coupled to the sliding flange of the variable-ratio pulley through a thrust-type ball bearing. The full function of the system is detailed in Section I, paragraph 3, Function of Component Assemblies.

## 2. Drive System

The drive system is composed of the following component assemblies:

- a. Variable-ratio Input Pulley
- b. Input Shaft
- c. Planetary Drive System
- d. Output Shaft

Figure 1 shows the power flow through the drive system of the supercharger. (A) is the variable-ratio input pulley. The fixed flange (A-1) of the

pulley is keyed to the input shaft (B) through a splined hub. The sliding flange (A-2) of the pulley is fitted with a splined bushing to permit constant drive of the input shaft through the full limit of travel of the flange. Movement of the sliding flange is controlled by an air piston (J) working in an air chamber, or cylinder. (Refer to Section I, paragraph 3a, Variable-ratio Input Pulley) Minimum ratio, offered to the driving pulley, exists when the two flanges are closed. Maximum ratio is presented when the sliding flange has moved away from the fixed flange the full limit of its travel.

A ball drive (C) is a component part of the input shaft assembly. It serves only to rotate the five drive balls (D) of the planetary system around the inner faces of the ball races (E). The clutch disc (F) prevent the ball races from turning in their respective mounts.

As the drive balls (D) revolve around the cage formed by the two races (E), they also rotate around their individual axes. This latter motion is transmitted directly to the output shaft (G), causing it to rotate. As the output shaft serves as the inner race of the planetary system, the system ratio is calculated between the inner diameter of the ball races and the raceway of the output shaft.

The impeller wheel (H) is attached to the end of the output shaft by a retaining hex-head

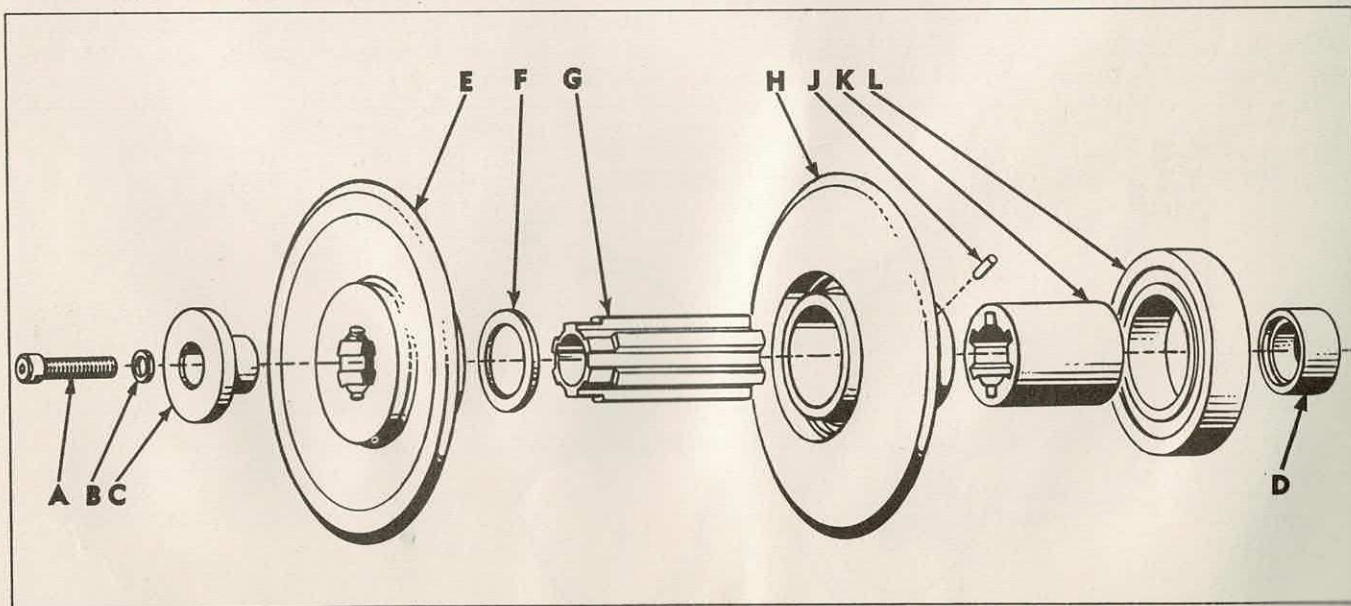

**FIG. 2 PARTS OF THE VARIABLE RATIO PULLEY**

A—Pulley Attaching Screw  
B—Lock Washer  
C—Retainer  
D—Shaftseal Spacer  
E—Fixed Pulley Flange  
F—Washer

G—Splined Hub  
H—Sliding Pulley Flange  
J—Pin  
K—Splined Bushing  
L—Ball Bearing

screw.

### 3. Function of Component Assemblies

#### a. Variable-ratio Input Pulley

The component parts of the variable-ratio pulley are shown in Figure 2. A socket-head cap screw, lockwasher and retainer serve to hold the overall assembly to the input shaft.

The fixed flange is internally splined to fit the splined hub which is keyed to the input shaft. The flange does not move and serves only as a working face to the sliding flange.

The sliding flange has a splined bushing insert that permits the flange to slide along the surface of the hub and still continue driving the input shaft.

A sealed, thrust-type ball bearing, fitted to the rear of the sliding flange, is used to transfer movement of an air piston to the flange to accomplish ratio shifting of the pulley.

Shifting of the variable-ratio pulley is accomplished by the combined functions of the control system, an air piston, and the belt-tensioning arm and idler pulley. The shifting is automatic, as determined by engine load conditions. The control system is discussed in Section I, paragraph 5, Control System.

When the supercharger shifts from "high blower" to "low blower", it is a result of boost pressure

(taken from the discharge throat) being passed into an air chamber, or cylinder, containing the air piston. The pressure behind the piston (See Figure 3) drives it forward and the movement is transmitted to the sliding flange of the pulley assembly through a ball bearing. The pressure is sufficient to overcome the tension applied to the drive belt by the belt-tensioning arm and, as the pulley flanges close, the belt is forced to the top of the pulley and the speed of the input shaft is reduced. An equalizer spring behind the piston helps to overcome the effect of the tensioning arm against the drive belt.

NOTE: During idle speed engine operation, the drive belt and variable-ratio pulley are in the "high blower" position as there is insufficient boost pressure being developed to drive the air piston forward. As the engine speed is increased, the boost pressure out-put reaches the level required to drive the piston forward and shift the supercharger into the "low blower" range. The spring behind the air piston serves to equalize the tension exerted by the belt-tensioning arm against the drive belt, thereby holding the level of pressure (PSI) required for this function to a minimum.

During the shift cycle from "low blower", a valve in the control system closes to prevent boost pressure from entering the air chamber. The pressure within the chamber bleeds, or vents off, and the tension on the drive belt (exerted by the belt-tensioning arm) causes the belt to pull down into the pulley and separate the two flanges.

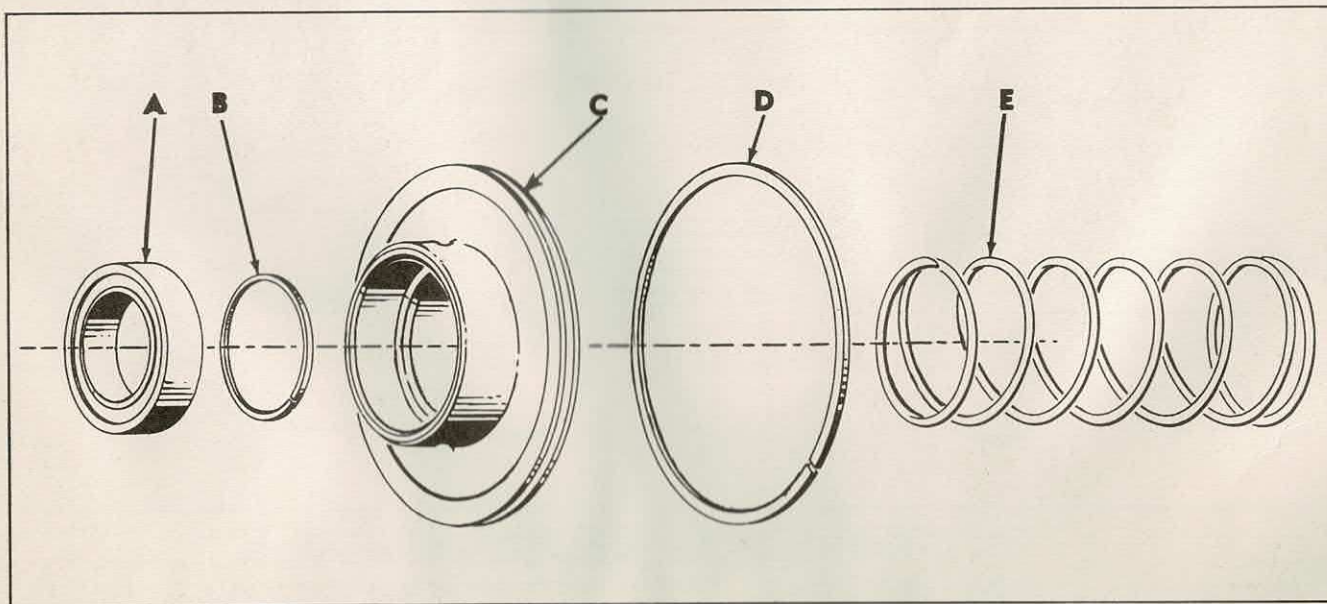

**FIG. 3 BLOWER CONTROL PARTS**

A—Ball Bearing  
B—Air Piston Inner Ring  
C—Air Piston

D—Air Piston Outer Ring  
E—Air Piston Spring

Computed against the Kaiser 7-1/2" diameter crankshaft pulley, the minimum ratio of the variable - ratio pulley is 1.3 to 1. The maximum ratio, when the flanges are fully separated, is 2.3 to 1.

The belt-tensioning arm, or idler arm, is mounted to the same bracket used to mount the supercharger. The spring-loaded arm is geometrically located with relation to the center line of the supercharger input shaft to apply tension, measured in pounds, to the drive belt. The existing design should not be altered in any way as it will affect the shifting cycles of the variable-ratio pulley.

### b. Input Shaft

The composite input shaft assembly as shown in Figure 4, is the central shaft in the drive system and is supported in the bearing housing by two ball bearings.

The oil pump assembly fits on the shaft between the two bearings. The plunger of the oil pump is actuated by a camway ground into the input shaft. A ball driver fastened to the rear of the input shaft by five screws, rotates the drive balls of the planetary drive system. A bushing, inserted in the input shaft, serves to pilot the output shaft. This bushing also has a function in the lubrication system. This is

explained in Section I, paragraph 4, Lubrication System.

The input shaft is keyed directly to the variable-ratio pulley and always turns at the RPM speed being turned by the pulley.

### c. Planetary Drive System

The component parts of the friction-type planetary drive system are shown in Figure 5. The ratio of the system remains constant under all conditions and is 1 to 4.44, input to output shaft.

When assembled into the supercharger, the drive balls are enclosed between and revolve around the inside faces of the two ball races. As the drive balls are turned (by the ball driver) around the races, they also revolve around their own axes. It is this revolving motion that is transmitted to drive the output shaft, as the output shaft forms the inner raceway of the planetary system. This is shown in Figure 6.

One ball race is fitted into the scroll housing and the second race is fitted into the collar of the race load assembly. A clutch disc is inserted behind each race to prevent the race from turning.

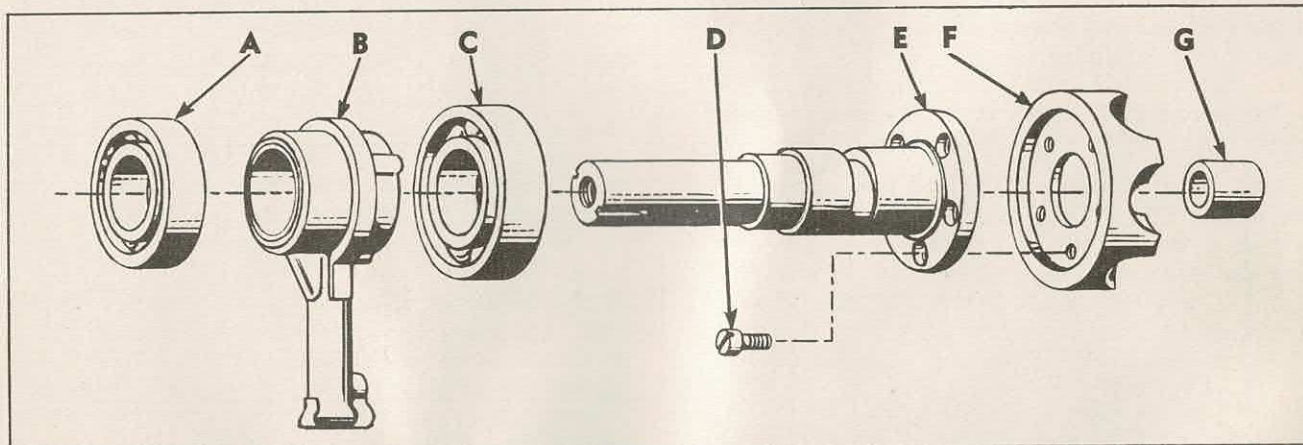

**FIG. 4 POWER INPUT SHAFT ASSEMBLY**

A—Ball Bearing  
B—Oil Pump  
C—Ball Bearing  
D—Screw

E—Input Shaft  
F—Ball Retainer  
G—Bushing

The race load assembly, through compression of internal springs when the supercharger is assembled, applies pressure evenly around the front ball race. (See Figure 7.) The contact point (A) is between the race load assembly and the bearing housing. Pressure is applied to the planetary system at (B), through the

clutch disc (C). As the ball race (D) is forced against the drive balls (E), the balls are pressed backward against the rear ball race and down against the raceway of the output shaft.

The design of the overall system provides for maximum drive with minimum slippage, while



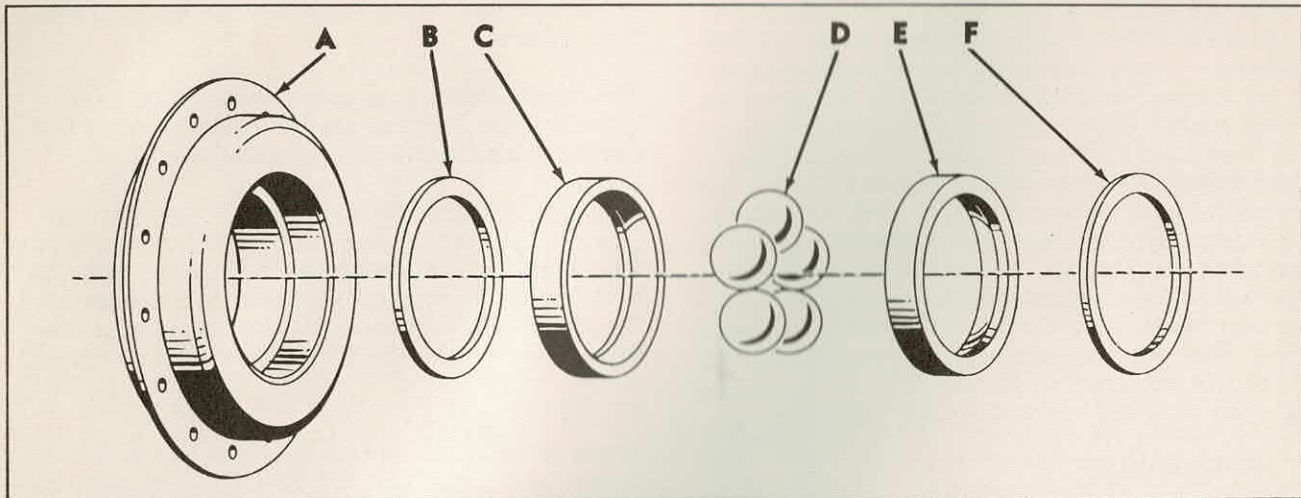

**FIG. 5 FRICTION TYPE PLANETARY DRIVE**

A—Race Load Assembly  
B—Clutch Disc  
C—Ball Race

D—Drive Balls  
E—Ball Race  
F—Clutch Disc

also providing for the take-up of any wear that might develop in the ball races or drive balls.

#### d. Output Shaft

The output shaft, as part of the drive system, is the rotating inner raceway of the planetary system. The ratio step-up of 1 to 4.44 therefore is calculated between the inner contact surface of the ball races and the outer contact surface of the output shaft.

A slinger ring (Figure 8) is pressed on the output shaft to aid in the prevention of loss of lubricant from the lubrication system. Two labyrinth rings, fitted into grooves of the lab-

yrinth section of the shaft, also serve to prevent the loss of lubricant.

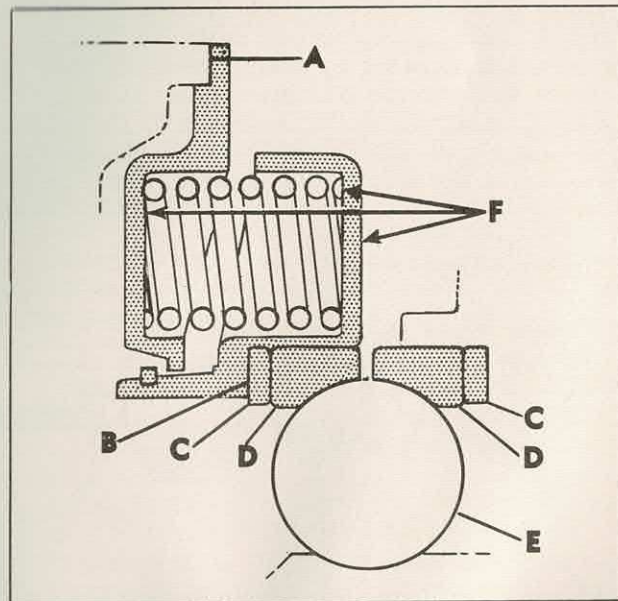

**FIG. 7 BALL RACE LOAD ASSEMBLY**

A—Spring Pressure Contact Point  
B—Pressure Applied to Planetary System  
C—Clutch Disc  
D—Ball Race  
E—Drive Ball  
F—Race Load Assembly

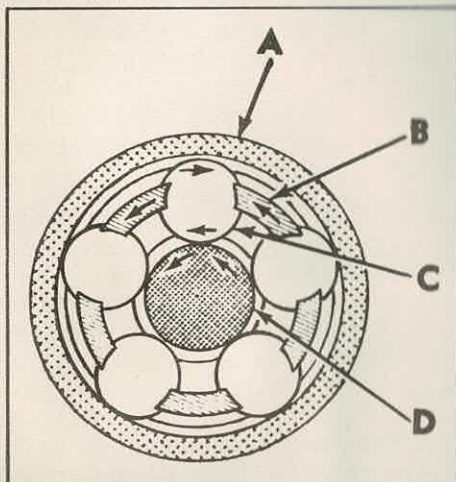

**FIG. 6 PLANETARY TYPE BALL DRIVE**

A—Stationary Ball Race  
B—Input Shaft Ball Driver  
C—Drive Ball  
D—Output Shaft

The impeller wheel fits onto a pilot hub on the end of the output shaft and is retained by a washer, a lockwasher and a hex-head cap screw. Two dowel pins pressed into the output shaft prevent the impeller wheel from slipping on the hub during acceleration or deceleration of the supercharger.

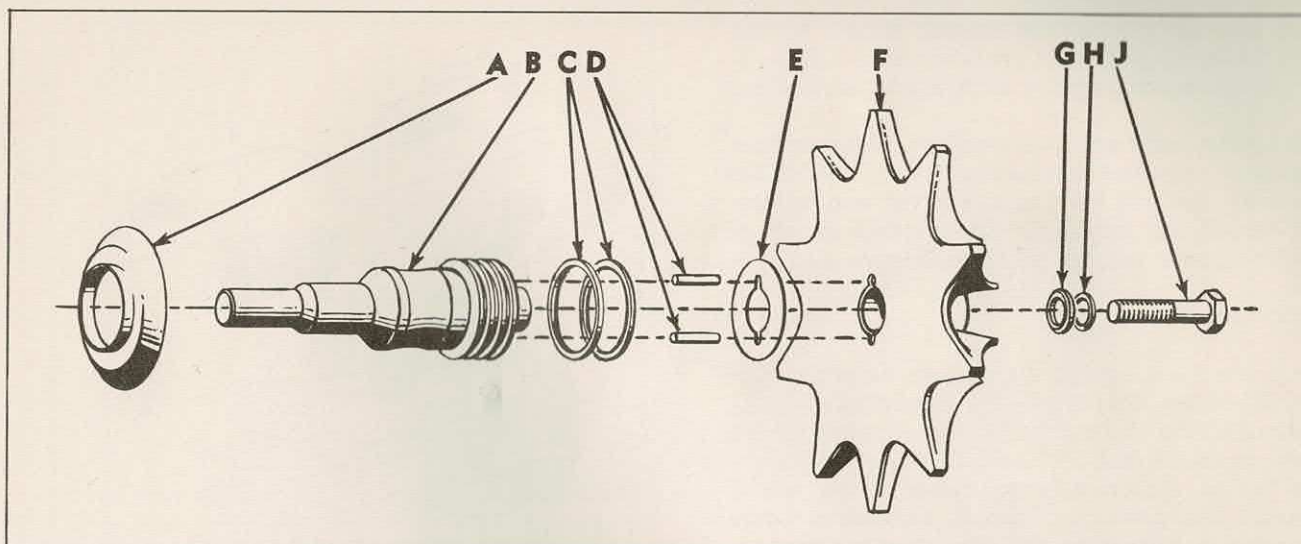

**FIG. 8 OUTPUT SHAFT ASSEMBLY**

A—Oil Slinger  
 B—Output Shaft  
 C—Labyrinth Ring  
 D—Dowel Pin  
 E—Shim

F—Impeller  
 G—Flat Washer  
 H—Lock Washer  
 J—Cap Screw

A shim, or shims, placed between the impeller wheel and the output shaft, provide for proper clearance between the back face of the impeller wheel and the face of the scroll housing. When the shims are correctly fitted the spacing between the vanes of the impeller wheel and the internal face of the scroll cover is automatically correct.

#### 4. LUBRICATION SYSTEM

The supercharger is self lubricated by a piston-type oil pump which works off a camway ground into the input shaft. The oil sump holds eight (8) ounces of lubricant. Use Automatic Transmission Fluid, Type A only.

**NOTE:** Never use any but this specified lubricant, as this lubricant is designed for high heat range applications. The use of standard automobile engine oil will result in oil breakdown and cause serious damage to the supercharger. Component parts of the oil pump are shown in Figure 9. A dip-stick oil gauge, marked to show "safe" operating level and "add oil" level of the lubricant, inserts in a sleeve located in the bearing housing.

The overall lubrication system is shown in Figure 10. In operation, oil pump (C) is fitted to the input shaft and extends down into oil sump (D). Plunger (B) follows a camway (P) ground into the input shaft. Spring (E) keeps the plunger in constant contact with the cam. As the plunger follows the low portion of the camway, oil is sucked through oil passageway

(F) and enters the chamber just at the bottom of the plunger. As the plunger is pushed down, the oil passageway is sealed off and the oil trapped in the lower chamber is compressed and forced up the hollow stem of the plunger.

**NOTE:** The small ball (G) is not a check ball, but serves only to seal the drill passage where it enters the body casting of the oil pump.

As the oil enters chamber (A), pressure is built up by the escape limitation imposed by clearance (O) existing between the insert bushing and the pilot boss of the output shaft. Thus, oil is forced out of the Chamber in the direction of arrows (M), and sprayed on the planetary system drive balls. Slinger (L) and labyrinth rings (K) prevent loss of lubricant into the diffuser section of the supercharger.

The spray of oil falls into the forward section of the oil sump (J). There, small holes (H) around the face of the race load assembly permit the oil to seek its own level within the sump. Ball bearings (N and Q) are lubricated by the existing oil spray and seepage of oil under the bushing of the oil pump. Shaft seal (R) prevents large quantities of oil from entering the front section of the supercharger and also serves to keep dirt out of the lubricating system. However, a small quantity of oil passes under and around spacer (S) to provide lubrication for the air chamber and air piston.

**NOTE:** The thrust-type ball bearing which

joins the air piston and sliding flange of the variable-ratio pulley is prelubricated and sealed and does not require additional lubrication.

Externally, only one point on the supercharger assembly requires lubrication. Every 1000 miles lubricate the oil hole at the pivot end of the belt-tensioning arm with one or two drops of current grade engine oil. See Figure 11.

### 5. Control System

The control system of the Kaiser supercharger regulates the output of the supercharger by controlling the movement of the sliding flange of the variable-ratio pulley. In effect, the system is an electrically operated valve which controls the passage of boost pressure, taken from the discharge throat, into an air chamber. A piston within the chamber is coupled directly to the sliding flange of the pulley through a thrust-type ball bearing.

The main electrical component of the system is a solenoid regulator which is energized by the closing of an external switch. Located in the bearing housing, the regulator intersects an air passage leading between the discharge throat and the air chamber. The external switch is a kick-down type switch mounted on the carburetor enclosure base and operated by the throttle linkage.

The solenoid regulator has three phases of operation, as shown in Figure 12.

Phase "A" - The solenoid regulator is not energized and the valve is open, permitting boost pressure to enter the air chamber. The air piston is driven forward, closing the variable-ratio pulley and the supercharger is operating in "low blower". Minimum horsepower is required to drive the supercharger during this phase, as the supercharger is not producing high level output. This phase extends across the cruising range of the engine, where the engine does not demand, and cannot use, boost pressure. Under acceleration or full load demand or the engine, the supercharger shifts into Phase "B" operation.

NOTE: Phase "B" operation is initiated when the accelerator is depressed sufficiently to cause the throttle linkage to close the contacts of the kick-down switch.

Phase "B" - As soon as the solenoid regulator is energized, the armature lifts and seals against the valve stem to block the passage of boost pressure to air chamber. When the source of constant pressure is removed from behind the air piston, the pressure that exists

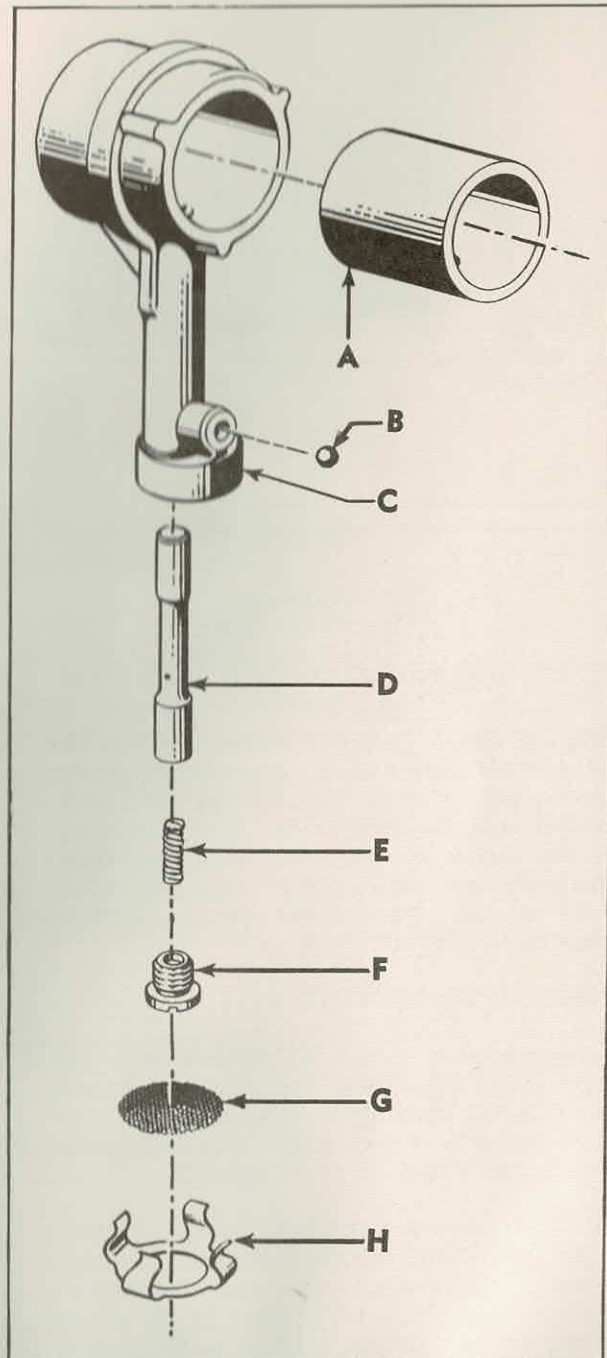
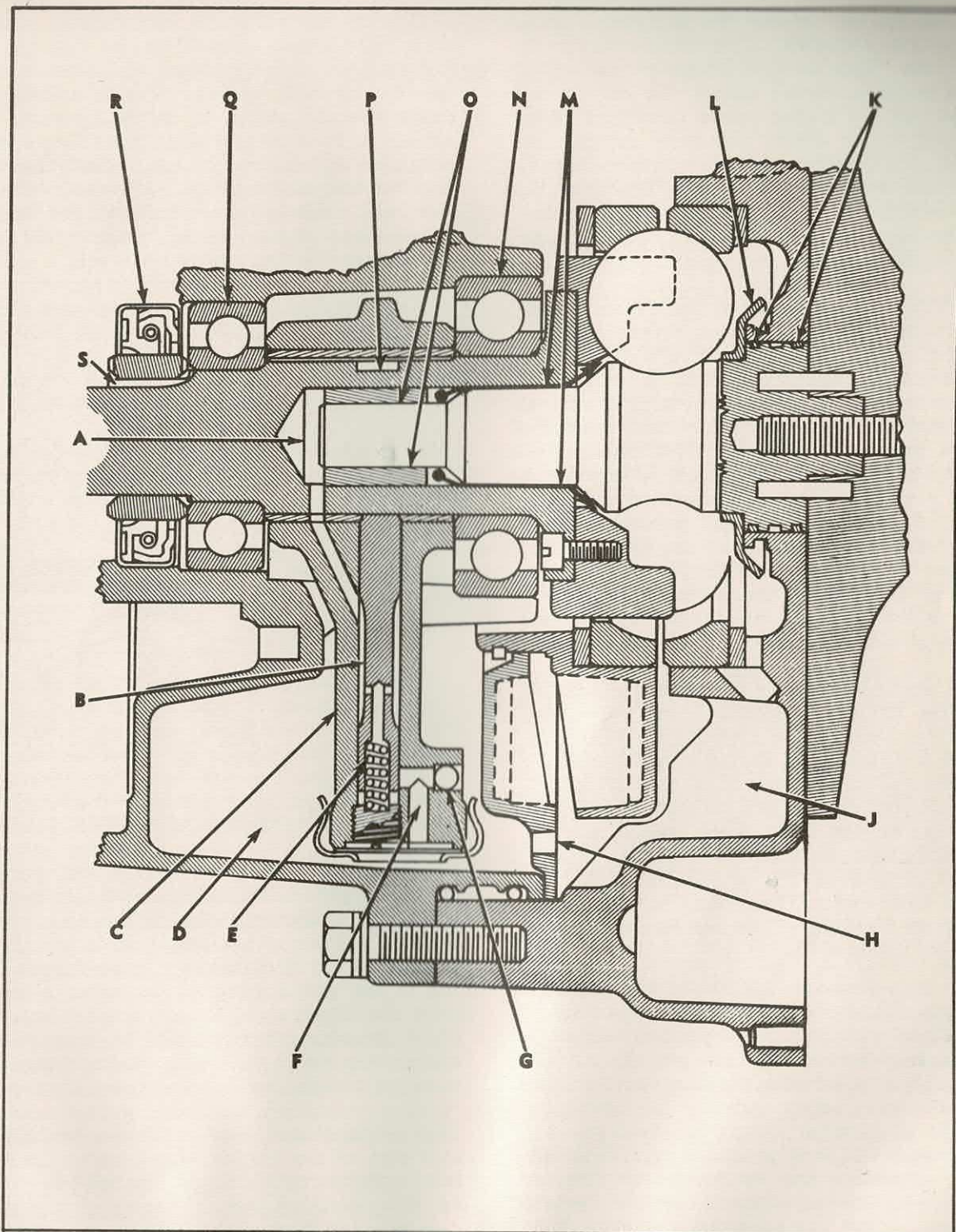

FIG. 9 OIL PUMP ASSEMBLY

- A—Bushing
- B—Ball
- C—Pump Body
- D—Pump Plunger
- E—Plunger Spring
- F—Spring Retaining Plug
- G—Screen
- H—Screen Retainer

in the chamber vents off. This permits the tension exerted against the drive belt by the belt-tensioning arm to pull the belt down into the variable-ratio pulley and move the sliding



**FIG. 10 LUBRICATION SYSTEM**

- |                               |   |
|-------------------------------|---|
| A—Oil Pressure Chamber        | K—Labyrinth Rings                           |
| B—Pump Plunger                | L—Oil Slinger                               |
| C—Oil Pump Assembly           | M—Direction of Oil Flow                     |
| D—Oil Sump                    | N—Ball Bearing                              |
| E—Pump Plunger Spring         | O—Bushing to Shaft Clearance                |
| F—Oil Intake Passage          | P—Input Shaft Camway                        |
| G—Drill Passage Sealing Ball  | Q—Ball Bearing                              |
| H—Oil Return Passage in Sump  | R—Shaft Seal                                |
| J—Forward Section of Oil Sump | S—Oil Passage for Lubrication of Air Piston |

flange backward, driving the air piston back into the air chamber. The supercharger is now in the "high blower" range of operation and the boost pressure output, in PSI, is increased. As the engine speed increases under full throttle, the boost pressure output also continues to increase until it reaches a predetermined level, as based upon that which the engine can safely use. At this time the solenoid regulator enters Phase "C" operation, to regulate the output of the supercharger.

**Phase "C"** - The design of the supercharger and drive system is such that maximum boost pressure output is produced at a crankshaft speed below maximum engine RPM. This permits production of usable boost pressure at lower engine speeds and also increases the range of engine speeds over which usable boost pressure is produced. However, if maximum output is produced at a mid-range speed of the engine, it is obvious that pressure output would continue to increase as the engine speed increases to maximum RPM. Therefore, it is necessary to regulate the pressure output, in PSI, to a level that is compatible with engine design and available fuel.

This is accomplished by a diaphragm located within the solenoid regulator case. A spring on the top side of the diaphragm is adjustable and the change of spring rate determines the pressure, in PSI, required to distend and lift the diaphragm. As the diaphragm is positioned against the head of the valve, any upward movement permits the valve to lift off the seat formed by the armature. It is this function that forms the Phase "C" operation of solenoid regulator. The mechanical operation is as follows:

During "high blower" operation, the solenoid is energized and the armature has moved upward to seal the passage of pressure into the air chamber behind the air piston. As the engine speed continues to increase and the boost pressure output reaches the level for which the diaphragm spring has been pre-set namely, four PSI, any pressure gain over four pounds will cause the diaphragm to distend. This permits the valve to lift off the seat to the same degree and open the passageway to the air chamber to allow boost pressure to enter the chamber. As the equalizing spring

behind the air piston is compressed, neutralizing the tension exerted by the belt-tensioning arm, the small amount of pressure passing the partially opened valve is sufficient to cause the air piston to move forward. This action, in turn, causes the sliding flange of the pulley to move forward and reduce the working diameter of the pulley. As the ratio changes, the input shaft speed is reduced, the impeller wheel slows down and the boost output pressure returns to the regulated level.

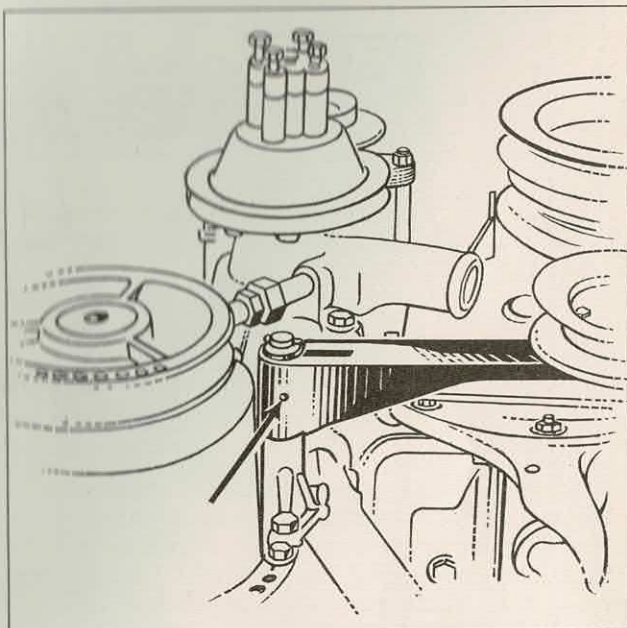

FIG. 11 TENSIONING ARM LUBRICATION

At this point, with the valve still partially opened and the pulley semi-closed, any increase in engine speed will also increase the boost pressure output. This will reflect in greater distension of the diaphragm and a larger opening in the passageway as the valve stem follows the diaphragm. A still greater volume of boost pressure is permitted to enter the air chamber to again drive the sliding flange forward to reduce the ratio of the driven pulley.

This regulating action continues through the high end of the engine speed curve until the full limitation of the diaphragm has been reached. However, the overall design of the supercharger and control system is such that the limit of regulation holds very close to the maximum usable engine RPM.

## SECTION II

### REMOVING SUPERCHARGER FROM ENGINE

The supercharger is more easily removed from the engine as an assembly, with the mounting bracket and belt-tensioning arm attached. To remove the whole unit, proceed as follows:

1. Drain the cooling system to a point where the coolant level is below the cylinder head.
2. Push the belt-tensioning arm toward center of engine and remove the V drive belt.
3. Loosen the hose clamps and disconnect the rubber outlet hose to the carburetor enclosure at the supercharger.

4. Disconnect the kick-down switch to solenoid regulator wire at the slip connector.

5. Disconnect the pressure line from the supercharger throat to the fuel pump at the fitting on the supercharger throat.

6. Remove the bolt attaching the fuel line bracket to the supercharger mounting bracket.

7. Remove the four (4) cylinder head cap screws from the supercharger mounting bracket and remove the supercharger assembly from the engine.

## SECTION III

### DISASSEMBLY

With the supercharger assembly off the engine, remove the belt-tensioning, arm and spring. This is done by removing the retaining snap rings and washers from both the tensioning arm pivot shaft and the tensioning spring mounting shaft. With the retaining snap rings and washers removed, pull the tensioning arm and spring off the shafts.

Inscribe a small mark, for correct reassembly, on the supercharger bearing housing opposite each of the three remaining mounting bracket bolts, then remove the bolts and the mounting bracket.

The supercharger is now ready for disassembly but before starting disassembly work the technician should become familiar with the following precautionary measures and observe them during all phases of repair and maintenance.

**CLEANLINESS** - Work only upon a clean, hard surfaced bench. All tools and wiping rags should be free of dirt and deposits of oily grit. Also, all containers should be clean and only fresh, clean solvents and oils should be used.

**PROPER TOOLS** - The use of proper tools will reduce the possibility of damage occurring during disassembly and assembly procedures. The supercharger is a precision built engine accessory and "brute force" is not required for maintenance and repair work.

**RUST AND OXIDATION** - The working surfaces of the drive assemblies are micro-finished and the presence of either rust or oxidation will seriously damage the parts. For this reason, never handle the output shaft, drive balls, or ball races, barehanded. Instead, wear clean, dry gloves or use well oiled patches of clean cloth to handle the parts. If available, lint-free paper wiping towels can be used for this purpose.

**STEEL WOOL AND ABRASIVES** - Never use steel wool or any form of abrasive material to clean the input and output shafts, drive balls or ball races, as such practice will destroy the micro-finish. Surface aberrations or pits, regardless of size, will result in noisy and rough operation and cause ultimate failure of the supercharger.

**SHORT CUTS** - There are no short cuts when you are working on precision equipment. Therefore, carefully follow all phases of the instruction information and you will avoid trouble.

All repair work must be performed with the supercharger removed from the engine. Any accumulation of oil, dirt or grime should be removed from the exterior surfaces by application of cleaning solvent and wiping with rags or industrial wipers. **DO NOT** immerse the supercharger in the solvent as damage to the solenoid regulator will result. Also, avoid the use of compressed air during this cleaning operation.

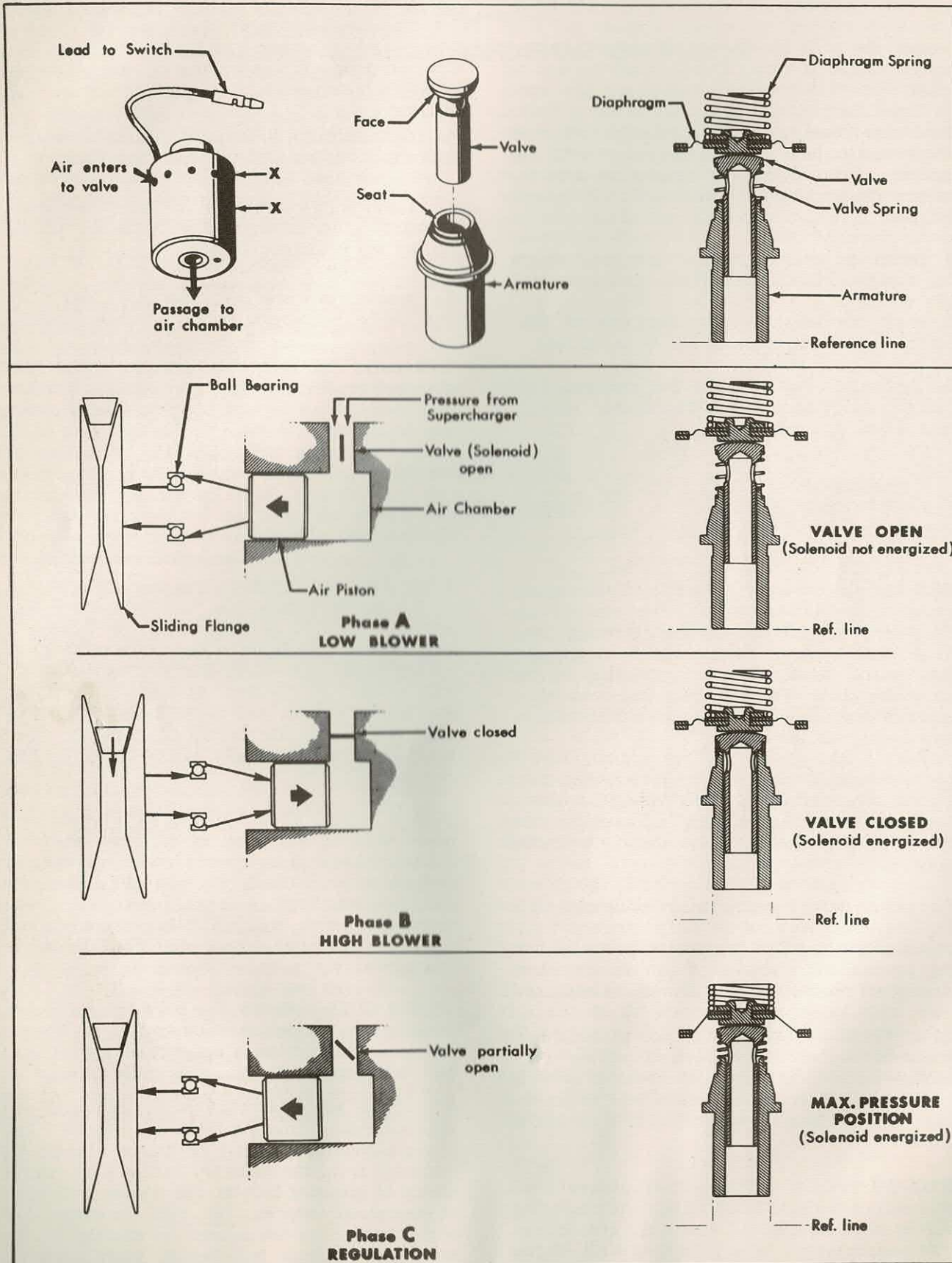

FIG. 12 SOLENOID REGULATOR OPERATION

## 1. REMOVAL OF VARIABLE-RATIO PULLEY

Remove the oil gauge dip-stick and empty the lubricant from the oil sump. Remove the cap screw, lockwasher and retainer and then pull the fixed flange assembly off the input shaft. Should the fixed flange pull off of the splined hub, remove the sliding flange by pulling it straight off the splined hub, then remove the hub from the input shaft with Tool No. KW - 159 as shown in Fig.13. (The presence of binding during removal of the sliding flange is caused by the fit-up between the ball bearing and the air piston. Pulling firmly on the flange will free the bearing from the air piston.)

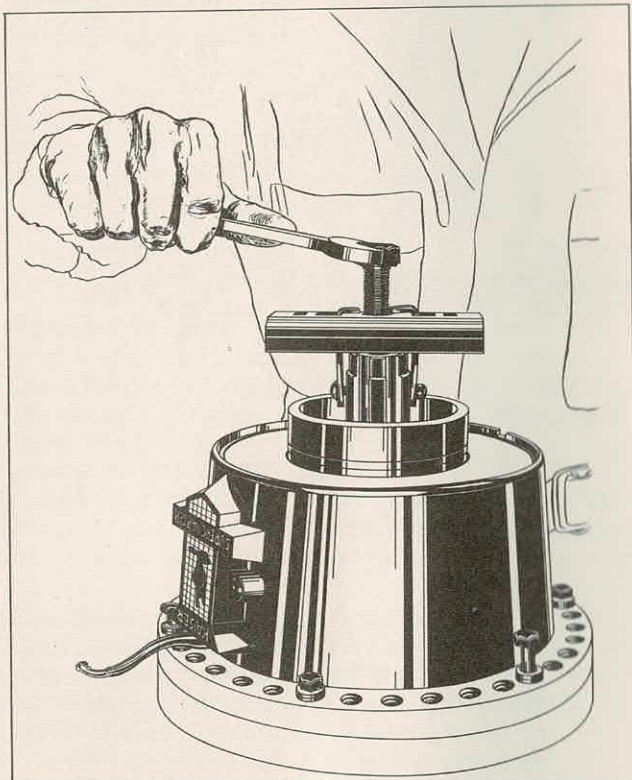

FIG. 13 HUB AND BEARING REMOVER

## 2. AIR PISTON AND SPRING REMOVAL

Push in on the hub of the air piston to compress the piston spring and remove pressure from the air piston cover. Insert a screw driver in the notch in the bottom of the bearing housing and snap out the outer retaining ring. Remove the air piston cover and then snap out the inner retaining ring.

**CAUTION:** During removal of the retaining rings and air piston cover, the air piston must be held down constantly. After the inner retaining ring is removed, let the air piston come up slowly until the piston spring is fully extended. This will prevent the possibility of personal injury resulting from the coil-

ed piston spring forcibly ejecting the air piston from the air chamber.

The air piston and the piston spring can now be lifted from the air chamber of the bearing housing.



FIG. 14 IMPELLER HOLDING WRENCH

## 3. DISASSEMBLY OF BEARING AND SCROLL HOUSING

Remove the medallion and the solenoid regulator retaining spring. Remove the solenoid regulator from the bearing housing by grasping the top shoulder of the regulator with vise-grip



FIG. 15 IMPELLER PULLER



pliers and then pulling straight out. Remove the two sealing "O" rings from the solenoid regulator well. Remove the scroll cover by first removing the retaining screws and then lifting, not twisting, the cover from the housing.

Hold the impeller wheel with the special holding tool, No. KF-156, Figure 14 and remove the hex-head retaining screw. Insert the impeller wheel puller, No. KF-158, Figure 15, into the impeller and turn it clockwise until the impeller wheel is lifted clear of the output shaft boss. Remove the impeller wheel shim, or shims.

**CAUTION:** The impeller wheel is precision machined and balanced to permit turning safely at speeds in excess of 25,000 RPM. Any chipping, deep surface scratches or gouging, will destroy the balance and can result in serious damage when the supercharger is re-assembled and operated. Therefore, do not use pliers to hold the impeller wheel while removing the retaining screw. Also, do not use a screw driver, or other tool, to pry the impeller wheel off the output shaft.

Should the impeller wheel be chipped or badly gouged, do not attempt to dress out or repair the damage but, instead, replace the part. This is the ONLY safe practice under such conditions.

Replace the scroll cover on the housing and secure it with four (4) of the retaining screws, lockwashers and flat washers placed equally around the rim.

**NOTE:** The flat washers must be placed between the lockwashers and the surface of the scroll cover to prevent hogging or gouging the cover. Fit the supercharger into the special assembly Jig, No. KW-157, Figure 16, and remove the retaining hex-head screws, lockwashers and flat washers. Remove the bearing housing by twisting it free of the scroll housing. After the housings are separated, remove the two sealing "O" rings from the bearing housing.

**CAUTION:** Do not use a screw driver or other tool to pry the housings apart. To do so will result in either breaking out a section of the side wall of the scroll housing, or gouging of the mating surfaces of the housings. The latter, while not appearing serious, can cause the loss of concentricity when the housings are reassembled and result in damage to the drive system. Also, never rock the bearing housing back and forth to loosen or remove it. If the

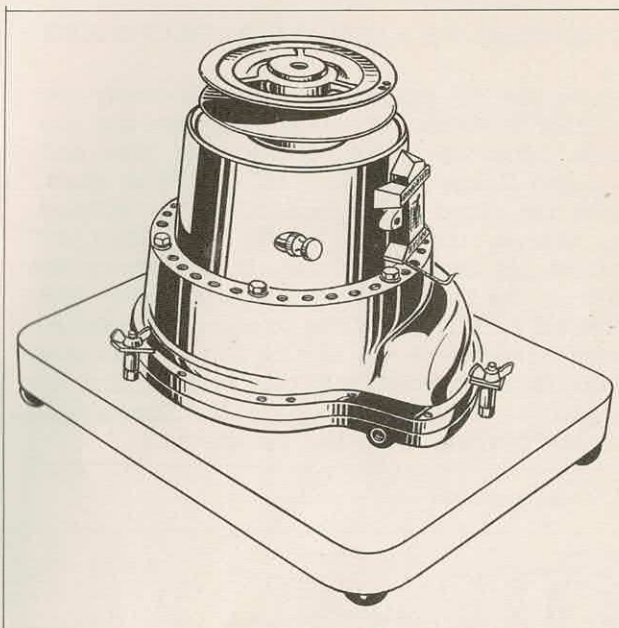

**FIG. 16 ASSEMBLY AND DISASSEMBLY JIG**

housing is rocked during the removal procedure, it may result in bending or damaging the input and output shafts and bearings.

#### 4. REMOVAL OF INPUT AND OUTPUT SHAFTS

**NOTE:** Before proceeding, read the following four paragraphs carefully.

- (a) Handle the internal moving parts carefully. Do not "throw" the drive balls, ball races or other parts into containers. Pits, scratches or surface aberrations will result in noisy operation and ultimate failure of the supercharger.
- (b) Do not handle the steel parts with bare hands. This can result in rusting and oxidation which will necessitate the installation of new parts.
- (c) To prevent rusting, keep the internal steel parts submerged in a bath of clean oil following removal. This is very important if the existing oil film is removed by washing with gasoline or cleaning solvent.
- (d) Do not use steel wool or other abrasive material to clean or polish the contact surfaces of the planetary system. Once rust or oxidation has attacked the metal, the parts must be replaced, not just cleaned and polished.

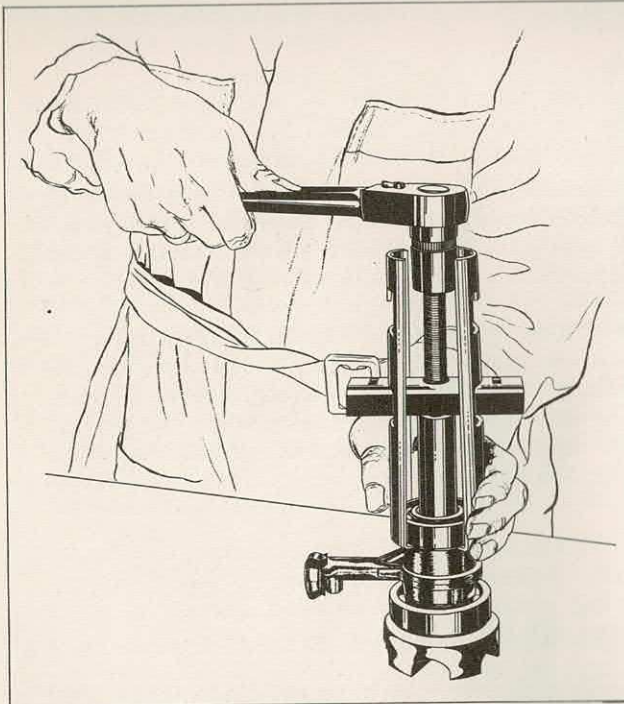

**FIG. 17 REMOVING INPUT SHAFT OUTER BEARING**

Remove the input shaft and oil pump assembly. If the shaft and pump assembly remained in the bearing housing when it was lifted free of the scroll housing, tap the pulley end of the input shaft with a rubber mallet to drive the assembly out of the housing.

Remove the race load assembly from its position in the scroll housing.

**CAUTION:** Do not attempt to disassemble the race load assembly without the use of an arbor press. The internal springs are exerting sufficient force to cause personal injury or damage to the assembly if released suddenly.

Remove the drive balls of the planetary system by lifting the output shaft until the balls are free of the rear ball race. The output shaft can then be removed by pulling it free of the scroll housing.

The ball races and clutch discs can be removed by lifting them from their respective seats in the race load assembly and the scroll housing. Should they bind, do not attempt to drive them out but, instead, heat the surrounding metal to an approximate temperature of 110 degrees and the resulting expansion of the metal will free the ball races.

## 5. DISASSEMBLY OF INPUT SHAFT AND OIL PUMP

Remove the hub key and the shaft-seal spacer from the input shaft. Use the bearing puller,

No. KW-159, Figure 17, to pull outer bearing from the shaft. Spring the screen retainer off the lower end of the oil pump and then remove the screen.

Screw out the slotted-head plunger spring retainer and shake the coil spring out of the pump body. If the pump plunger or piston failed to shake out, hold the pump body steady and rotate the input shaft until the plunger is at the high point of the cam. The pump body will now be free to slide off the input shaft.

**CAUTION:** Do not try to force the pump body off the shaft. Any binding will be caused by the pump plunger hanging in the camway of the input shaft, and several revolutions of the shaft will serve to free it.

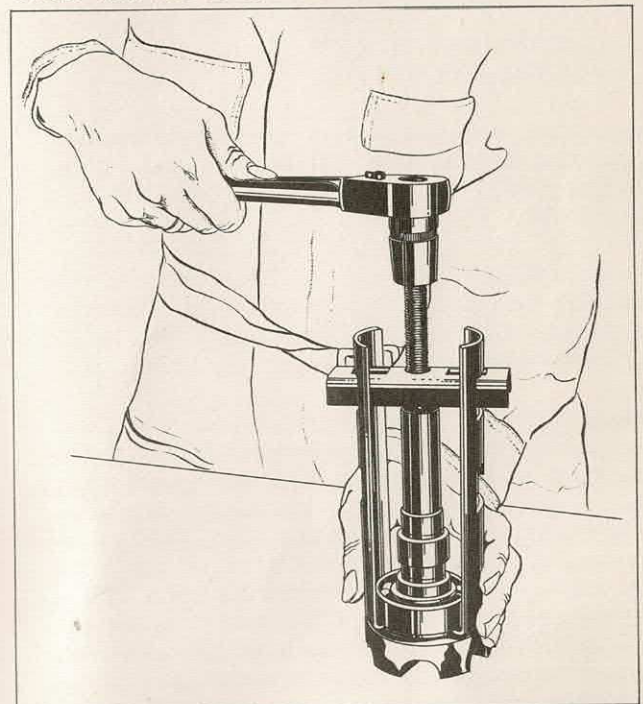

**FIG. 18 REMOVING INPUT SHAFT INNER BEARING**

Remove the bushing from the body by pushing it out in the direction of the staking tang. The small ball at the foot of the pump is staked in place and serves only to seal the drill passageway.

The last ball bearing on the input shaft may now be removed. Use the bearing puller, No. KW-159, Figure 18, for this operation. The ball driver can be removed by backing out the five (5) retaining screws.

## 6. SOLENOID REGULATOR ASSEMBLY

The solenoid regulator should not be disassembled. In the event of failure, the unit must be replaced. Instructions for properly adjusting a replacement solenoid regulator are given in Section VI, Solenoid Regulator Adjustment.

## SECTION IV

### ASSEMBLY

#### 1. INTRODUCTION

Before starting assembly work, the work area should be well cleaned and all dirty rags or towels removed. The external and internal components of the supercharger should be cleaned and free of dirt and deposits of oily grit. When assembling the internal drive parts, particularly the planetary system, even lint and dust should be held to an absolute minimum. Also all moving parts should be oiled as they are assembled.

#### 2. OUTPUT SHAFT AND PLANETARY SYSTEM

Install the scroll cover on the scroll housing, retaining it with four (4) screws and fit the housing into the assembly jig, No. KW-157, Figure 16.

Place a clutch disc into the seat of the scroll housing and press a ball race into position over the clutch disc. The ball race should fit snugly and bottom against the clutch disc.

Assemble the labyrinth rings into the first and third grooves of the output shaft, keeping the gaps of the rings in line with each other. Insert the shaft, dowel pins down, into the center opening of the housing. The shaft should be angled slightly, with the gaps of the rings up. Gently push the shaft into the opening and straighten to vertical in the same movement. A slight taper in the face of the opening, helps to compress the rings as the output shaft seats.

Lift the output shaft slightly and insert the drive balls into position on the rear race.

**NOTE:** Do not drop or force the balls into place. Instead, move the shaft from side to side and insert the balls gently into the ball race.

Insert a clutch disc and ball race into the race load assembly, making sure the race is well seated. Place the race load assembly into position, ball race down, over the drive balls.

#### 3. ASSEMBLY OF INPUT SHAFT AND OIL PUMP

Install the ball retainer, or driver, on the input shaft and tighten the retaining screws to

a minimum of 30 inch-pounds. Press the large ballbearing onto the input shaft until it is seated against the shoulder. Slide the oil pump body, with bushing insert, onto the shaft.

**CAUTION:** When installing the pump body, make sure the pump is not upside down before installing the outer ball bearing. That is, when correctly installed, the bore in the pump body will align with the camway ground into the input shaft.

Press the small ball bearing into place on the shaft. Assemble the plunger, plunger spring, spring retainer, screen and screen retainer to the oil pump body.

Install the assembled input shaft down over the pilot boss of the output shaft. Slowly rotating the shaft through several revolutions will cause the drive balls to seat properly within the ball retainer, or driver.

#### 4. ASSEMBLY OF BEARING HOUSING TO SCROLL HOUSING

Install the inner air piston ring on the boss of the bearing housing. Insert the input shaft seal into position inside the bearing housing. The seal should be inserted with the sealing face to the front of the supercharger. Install the sealing "O" rings (two (2) required) in the inside and outside grooves of the housing shoulder.

**NOTE:** Do not install the ring or rings in the center groove. This groove is part of the air passageway system and if it is blocked, the control system will malfunction. For ease of assembly, bearing housing to scroll housing, the "O" rings may be lightly oiled.

Install the bearing housing onto the scroll housing and secure it with six (6) hex-head screws, lockwashers, and flat washers. The hex-head screws should be tightened to 100 inch-pounds.

**NOTE:** The flat washers should be placed between the lockwashers and the bearing housing to prevent hogging or gouging of the housing.

**CAUTION:** Tighten the bearing housing down evenly. This will prevent any possibility of loss of concentricity between the drive system and the housing assemblies.

## 5. INSTALLATION OF AIR PISTON AND COVER

Install the outer air piston ring in the groove of the air piston. (Location of the gap is not important.) Place the air piston spring in the nose section of the bearing housing and then slide the air piston into place. Push in on the piston, depressing the spring, and install the rear retaining ring on the inside of the air chamber. (This ring will hold the air piston down until the cover and outer retaining ring are installed.)

Place the shaft sealing spacer over the pulley end of the input shaft and push it down into position under the shaft seal. Install the air cylinder cover and the outer retaining ring.

## 6. INSTALLATION OF VARIABLE-RATIO PULLEY

Slide the key into the keyway of the input shaft and then slide the splined hub into place on the shaft. Position the sliding flange of the pulley to the splined hub, and then push the flange down to seat the thrust bearing in the air piston. Insert the special spacer washer into the rear of the fixed flange of the pulley.

**NOTE:** The washer should be inserted with the chamfered inner edge at the rear of the flange.

Place the fixed flange in position on the splined hub and secure with the retainer, lockwasher and socket-head screw. The screw should then be tightened to 200 inch-pounds torque.

Depress the sliding flange of the pulley several times to check for the presence of binding. The flange should move up and down without binding or sticking.

## 7. INSTALLATION OF IMPELLER

The impeller should be fitted to the output shaft to show an approximate clearance of .012 inch between the rear of the impeller and the face of the diffusor section. Shims of varying thickness are available to readily accomplish this fitting.

Before measuring the depth of the face of the output shaft under the face of the diffusor section, the diffusor face should be wiped free of any foreign material. Several readings should then be made to determine the existing depth. Once this figure is obtained, .012 inch should be added to it as a basis for selection of shim, or shims.

**EXAMPLE:** The surface of the output shaft is determined .015 inch below the face of the diffusor section. When .012 inch is added (for clearance between the impeller and the diffusor face), it is seen that a shim .027 inch thick is required.

After determining the depth and correct shim, or shims to use, the impeller and shims are assembled to the boss of the output shaft. A flat washer, lockwasher and hex-head screw, tightened to 200 inch-pounds torque, are used to retain the impeller on the shaft.

A feeler gauge should now be used to check the clearance between the impeller and the diffusor face at several points around the impeller. The allowable tolerance of clearance is: .009 inch-Go; .016 inch-No Go. If the allowable tolerances are not obtained, the impeller will have to be removed and the shim, or shims refitted.

**CAUTION:** Before measuring the face depth of the output shaft, the supercharger must be assembled and all retaining screws between the bearing housing and scroll housing tightened to 100 inch pounds torque. The impeller retaining screw must be tightened to 200 inch-pounds torque before measuring for allowable tolerances.

Assemble the scroll cover to the scroll housing and tighten the retaining screws securely. A flat washer should be used between each lockwasher and the surface of the cover to prevent gouging.

## 8. SOLENOID REGULATOR

Lightly oil the two small "O" rings and install them in the channels within the regulator well. Position the regulator in the well and push it down until it is seated. Slip the retaining spring over the shoulder of the regulator and then install the medallion.

**NOTE:** The retaining spring must always be in place as it also serves to ground the regulator case to the supercharger.

**CAUTION:** Never operate the supercharger with the medallion removed. To do so can result in the solenoid regulator being blown from the well because of boost pressure present in the air chamber.

## 9. BELT-TENSIONING ARM AND MOUNTING BRACKET

Position the mounting bracket on the bearing

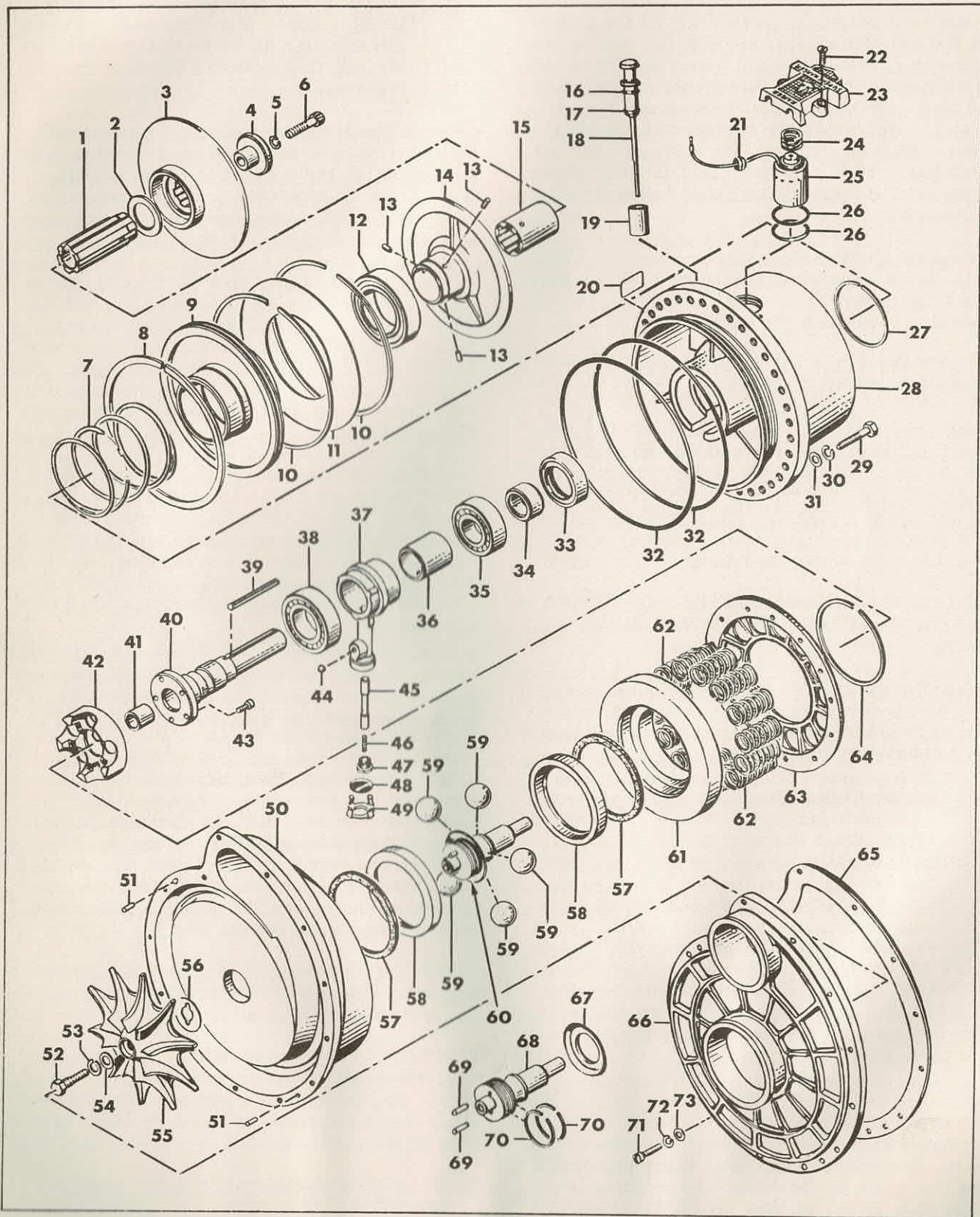

FIG. 19 SUPERCHARGER ASSEMBLY

## FIG. 19 THE SUPERCHARGER ASSEMBLY

1. Driven Pulley Hub
2. Driven Pulley Washer
3. Driven Pulley Fixed Flange
4. Driven Pulley Retainer
5. Lockwasher
6. Socket Head Screw
7. Air Cylinder Piston Spring
8. Air Cylinder Piston Outer Ring
9. Air Cylinder Piston
10. Air Cylinder Cover Retaining Ring
11. Air Cylinder Cover
12. Ball Bearing
13. Dowel Pin
14. Driven Pulley Sliding Flange
15. Splined Bushing
16. Oil Level Gauge "O" Ring
17. Oil Level Gauge Spring
18. Oil Level Gauge Assembly
19. Oil Level Gauge Sleeve
20. Decal
21. Grommet
22. Medallion Mounting Screw
23. Medallion
24. Retaining Spring
25. Solenoid Regulator Assembly
26. "O" Ring
27. Inner Air Cylinder Ring
28. Bearing Housing
29. Hex Head Screw
30. Lockwasher
31. Plain Washer
32. "O" Ring
33. Input Shaft Seal
34. Shaft Seal Spacer
35. Ball Bearing
36. Bushing
37. Oil Pump Body
38. Ball Bearing
39. Pulley Hub Key
40. Input Shaft
41. Input Shaft Bushing
42. Ball Driver Retainer
43. Input Shaft Screw
44. Ball
45. Oil Pump Plunger
46. Oil Pump Plunger Spring
47. Oil Pump Plug
48. Oil Pump Screen
49. Oil Pump Screen Retainer
50. Supercharger Housing
51. Dowel Pin
52. Hex Head Screw
53. Lockwasher
54. Plain Washer
55. Supercharger Impeller
56. Adjusting Shim
57. Ball Race Clutch Disc
58. Ball Race
59. Drive Ball
60. Output Shaft Assembly
61. Race Load Spring Cage—Front
62. Race Load Spring
63. Race Load Spring Cage—Rear
64. Snap Ring
65. Scroll Cover Gasket
66. Scroll Cover
67. Output Shaft Oil Slinger
68. Output Shaft
69. Output Shaft Dowel Pin
70. Output Shaft Labyrinth Ring
71. Fillister Head Screw
72. Lockwasher
73. Plain Washer

housing, aligning the correct holes up with the scribe marks made at disassembly. Insert the three attaching bolts in the proper holes and tighten them evenly and firmly.

Position the belt-tensioning arm on its pivot shaft and the tensioning spring on its mounting shaft. Secure both units with the washers and retaining snap rings on the shafts.

### 10. CHECKING

After the supercharger is assembled, it should be checked over before installing on the engine. The input pulley should be rotated several times to insure that there is no internal binding and that the impeller is not dragging against either the diffusor face or the scroll cover. During this check the pulley should turn rather hard, but should neither grab nor ratchet while being turned.

## SECTION V

### INSTALLING SUPERCHARGER ON ENGINE

1. Position the mounting bracket on the engine cylinder head and install the four (4) cylinder head cap screws. Torque screws to 30-35 ft. lbs.
2. Attach the fuel line bracket to the supercharger mounting bracket with the fourth attaching bolt.
3. Connect the pressure line from the fuel pump to the fitting on the supercharger throat.
4. Connect the solenoid regulator to kick-down switch wire at the slip connector.
5. Connect the rubber outlet hose to the supercharger and tighten the hose clamps.
6. Push the belt-tensioning arm toward center of engine and install the V drive belt around the crankshaft pulley, the input pulley and the idler pulley.

7. Refill the cooling system.

After the supercharger is installed on the engine, the oil sump should be filled with eight (8) ounces of Automatic Transmission Fluid, Type A. It is recommended that the input pulley be turned rapidly at least twelve (12) revolutions after the lubricant is added to prime the oil pump. This will prevent the possibility of a "dry" start.

The belt-tensioning arm should be checked for binding on the pivot shaft and one or two drops of current grade engine oil should be applied to the oil hole at the pivot end of the shaft.

Before adjusting the solenoid regulator the engine and the supercharger should be brought to operating temperatures. This first running of a reassembled supercharger should be done at idle speed until the oil pump is delivering sufficient pressure to insure adequate lubrication.

## SECTION VI SOLENOID REGULATOR ADJUSTMENT

### 1. INTRODUCTION

As explained in Section I, paragraph 5, Control System, regulation of the supercharger is controlled by a preloaded diaphragm in the solenoid regulator case. A small, socket-head screw can be turned in or out to either increase or reduce the tension of a spring resting against the top of the diaphragm. An increase in spring tension raises the level of boost pressure output at which regulation begins. A reduction of spring tension lowers the level of output at which regulation occurs. This makes it possible to adjust the boost pressure output to a level compatible with engine design.

### 2. DIAPHRAGM ADJUSTMENT

To accurately make the adjustment for regulation level it is necessary to read the pressure output of the supercharger, operating in "high blower", while the engine is turning 3400 RPM under load. This is done in the following manner:

After the car engine and supercharger have reached operating temperatures, the engine should be turned off and the tachometer and pressure gauge attached.

**NOTE:** The pressure gauge should be attached to the fuel pump pressure line fitting on the supercharger.

**CAUTION:** Because of the engine speed involved and the fact that the engine must be under load, the car must either be on a dyna-

nometer or actually driven when check readings are made.

Remove the medallion and retaining spring covering the regulator. Back out the adjusting screw (use a No. 564 Allen Key Wrench) until the head of the screw is flush with the top of the regulator. Now turn the screw in until it just contacts the spring collar within the regulator. This can be checked through the small hole next to the adjusting screw.

From this point turn the screw in three turns. Replace the retaining spring and medallion and start the car engine. Run the engine to 3400 RPM for 15 seconds and then read the indicated pressure which should be less than four (4) pounds (psi). Stop the engine and again remove the medallion and spring. Turn the adjusting screw out approximately 1/2 turn and again repeat the test for pressure.

The final point of adjustment will be reached when the pressure gauge indicates four (4) pounds (psi) of pressure, when the engine is turning 3400 RPM under load conditions.

**CAUTION:** Do not exceed a setting that provides boost pressure in excess of four pounds. At this setting a regulation tolerance of 3-1/2 to 4 1/4 psi exists, which is ample for the engine.

Once the correct setting has been reached, the adjusting screw should be cemented to prevent possible turning under vibration. No other adjustment of the solenoid regulator is required.



## SECTION VII KICK-DOWN SWITCH ADJUSTMENT

The supercharger kick-down switch mounted on the carburetor enclosure base actuates the solenoid regulator as described in Section I, paragraph 5, Control System.

With the switch connected to the throttle linkage, the switch contacts are closed when the throttle lever reaches  $13/32$  inches before full opening. Closing the switch energizes the solenoid and the solenoid armature lifts and blocks off the passage of boost pressure to the air chamber. With no boost pressure in the back of the air piston, the belt-tensioning arm pulls the belt down into the variable-ratio pulley, moving the sliding flange backward and driving the air piston back into the air chamber. This operation puts the supercharger into "high blower".

It now becomes obvious that the kick-down switch must always be in correct adjustment to insure a prompt and correctly timed shift into "high blower" when the accelerator pedal is fully depressed. To check the switch for proper adjustment, proceed as follows:

1. Install a 2 inch bolt in the throttle bracket as shown in Figure 20.
2. Lock two square nuts on the end of the bolt as shown in the illustration. The top nut should be turned on until end of bolt is flush with the top of nut and the right side of nut is perpendicular to the side of the enclosure hood. The

lower locked nut should be turned so a corner extends beyond the right side of the top nut.

3. Turn the lever to full throttle position.
4. Using the right side of the top locked nut as a guide and the lower locked nut as a rest, scribe a point on the enclosure hood as indicated (No. 1) in the illustration.
5. Using the same method, allow the lever to return toward the closed position until a second point may be marked  $13/32$  inches from the first point scribed (No. 2 in illustration).
6. From the  $13/32$  inches before full throttle position, to full throttle position the switch contacts should be closed. Checking with a test light, the light should not come on until the lever is  $13/32$  inches from full open throttle position (No. 2 in illustration). At the same time the lever must not travel past the  $13/32$  inch mark without lighting the test lamp. If it lights before or after the lever reaches the  $13/32$  inch mark, make the necessary adjustment at the switch adjusting nuts and/or switch mounting bracket.

**NOTE:** Should the lead wire from the kick-down switch be removed from the ignition coil for any reason, make sure that it is re-attached to the same post on the coil to which the ignition switch wire is attached.

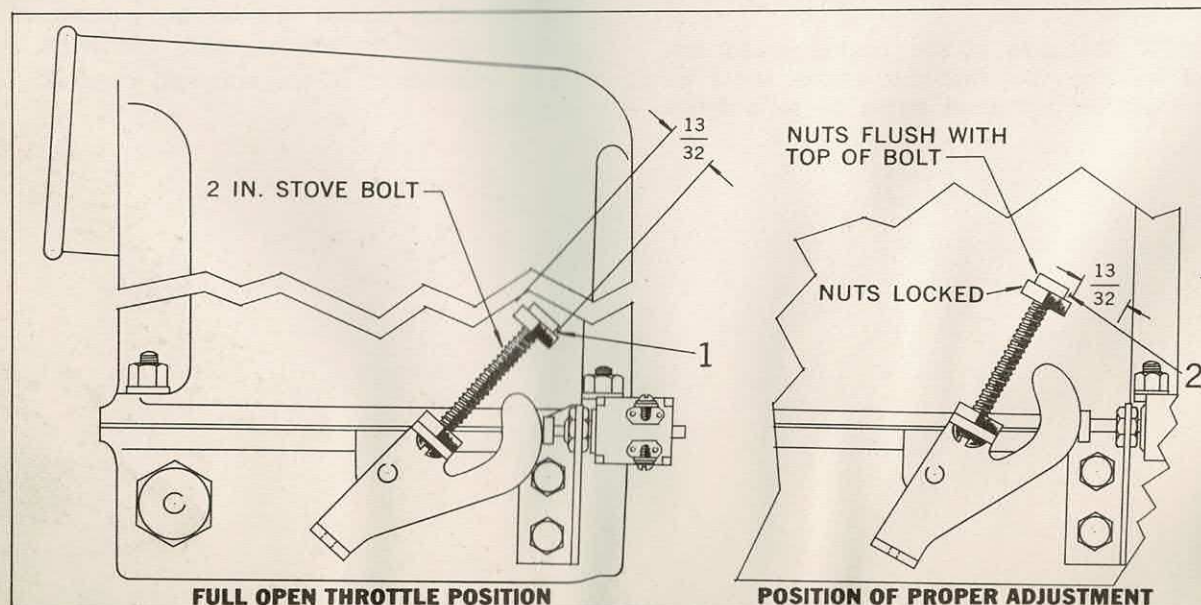

FIG. 20 KICK-DOWN SWITCH ADJUSTMENT

