

# The NEW 1953 FORD POLICE CAR

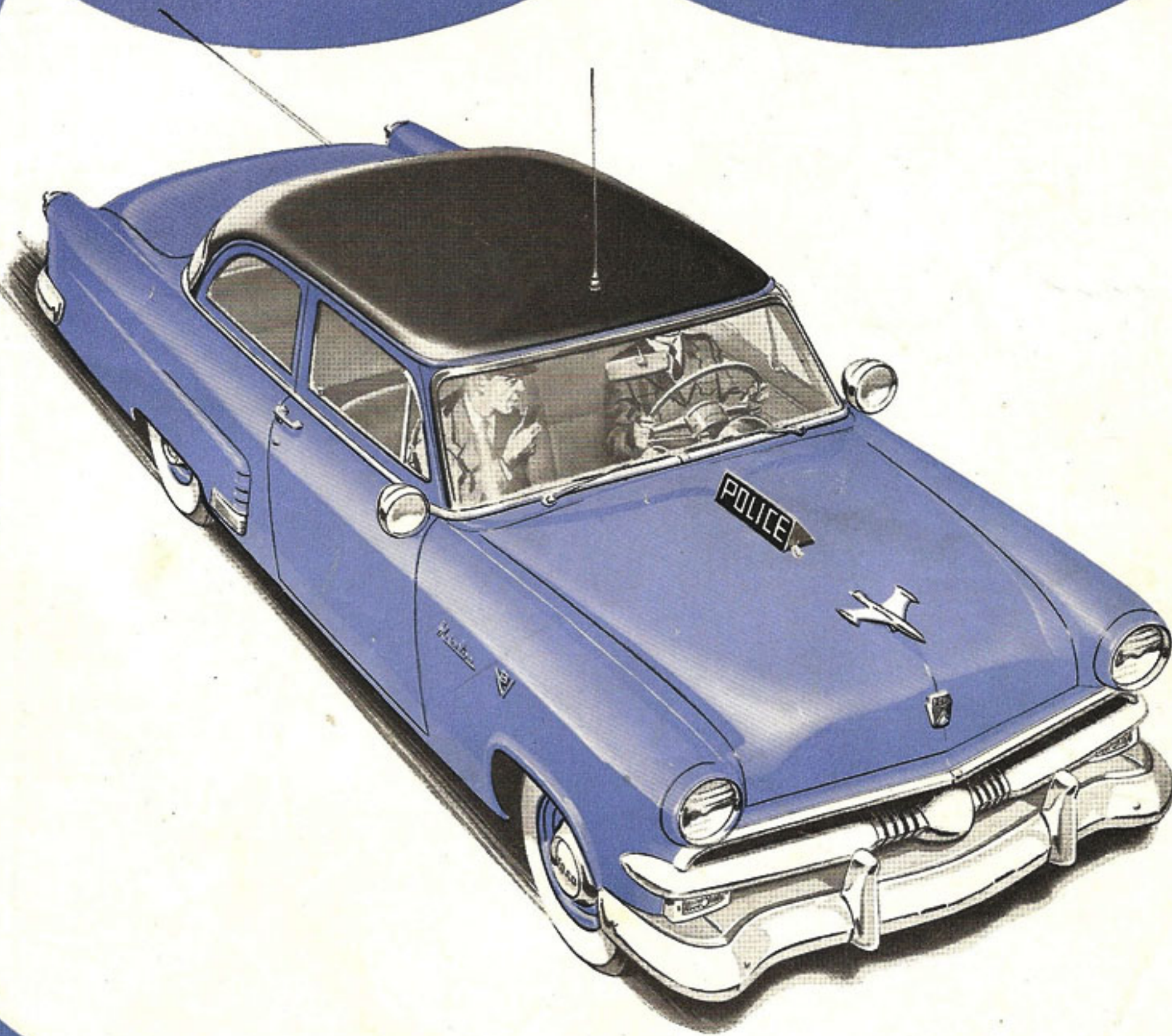

AVAILABLE WITH  
THE ADVANCED 125-H.P.  
"INTERCEPTOR" V-8!\*

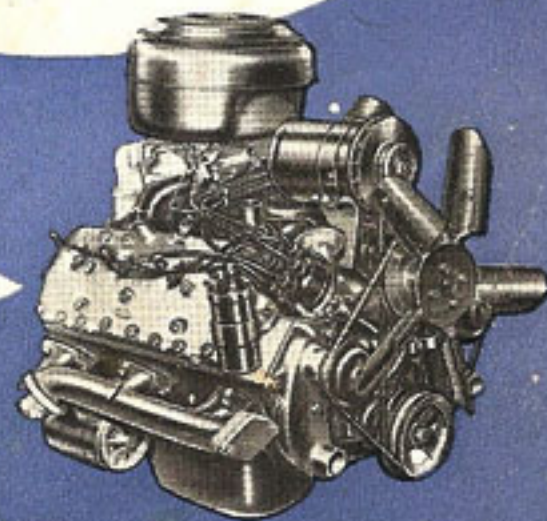

\*OPTIONAL AT EXTRA COST

# The FORD "INTERCEPTOR"...

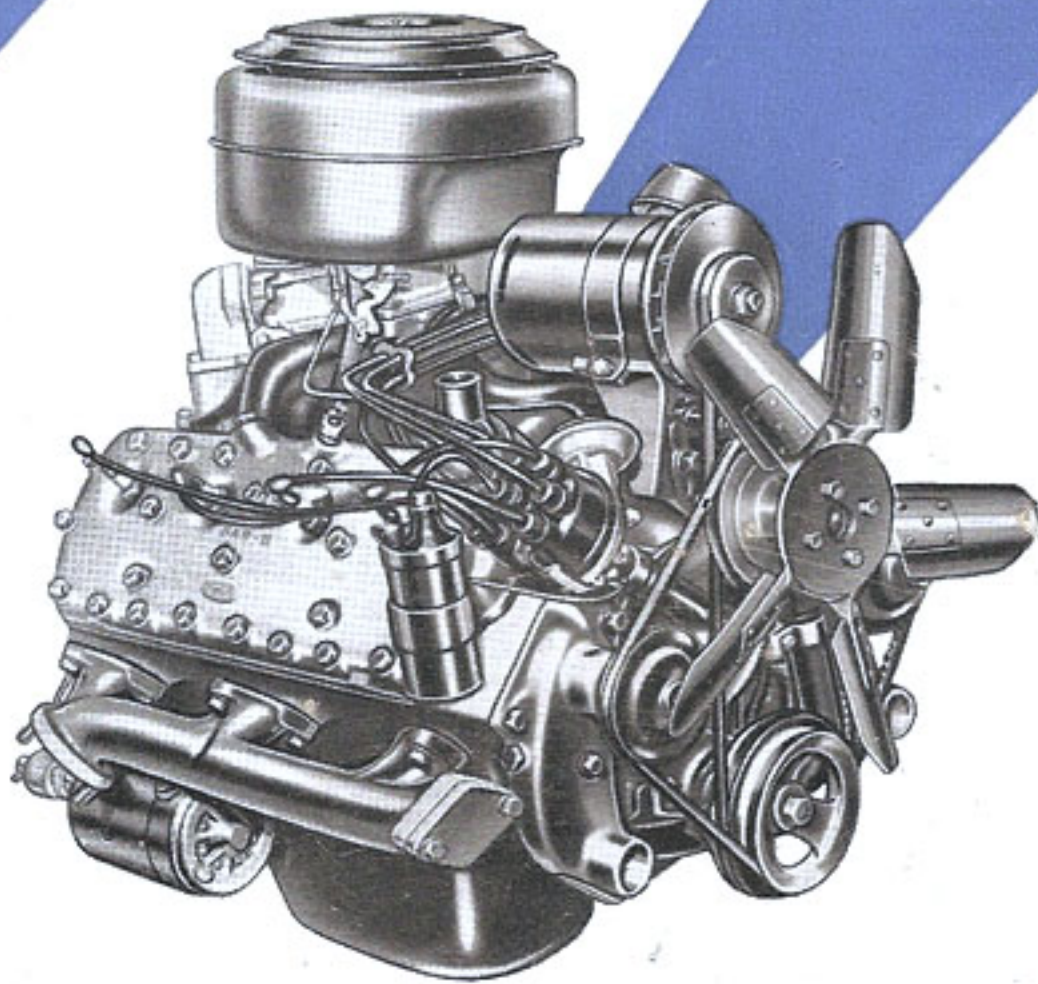

**A FAST,  
DEPENDABLE  
125-H.P. V-8  
...ideal for  
POLICE NEEDS!**

Police work demands the reliable power packed into this mighty, instant-responding "Interceptor" V-8 engine.

Here, in a proved high-compression design, is that *extra* acceleration for quick, smooth "take-offs" . . . that *extra* stamina for sustained runs at high speed. Along with its brilliant performance and flashing power, the "Interceptor" V-8 provides exceptional economy, too. One reason is Ford's famed Power Pilot that automatically meters the fuel, automatically fires the right amount of gas for every power requirement.

Other economy-wise features which offer fuel savings and long engine life are: the new dual exhaust system . . . the precision-built dual-downdraft carburetor . . . the super-fitted, 4-ring aluminum pistons . . . high-lift, rotating-type valves . . . Series-Flow type cooling . . . full-pressure lubrication . . . Full-Flo fuel pump . . . and Waterproof Ignition System. The engine also comes equipped, at extra cost, with a heavy duty radiator core, extra capacity 5-blade fan, vacuum booster unit for positive wind-

shield wiper operation (particularly at low speeds and during acceleration), oil filter, and oil bath cleaner.

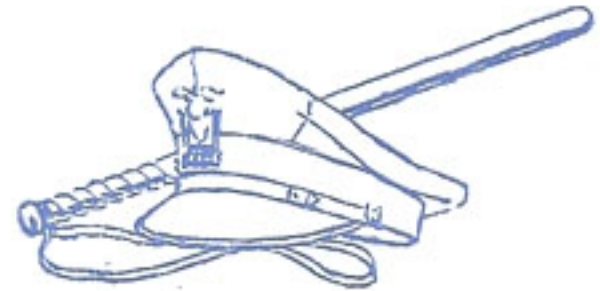

HIGH-COMPRESSION  
POWER-CONTOURED  
COMBUSTION CHAMBERS

LEVEL-MOUNTED  
INTAKE MANIFOLD

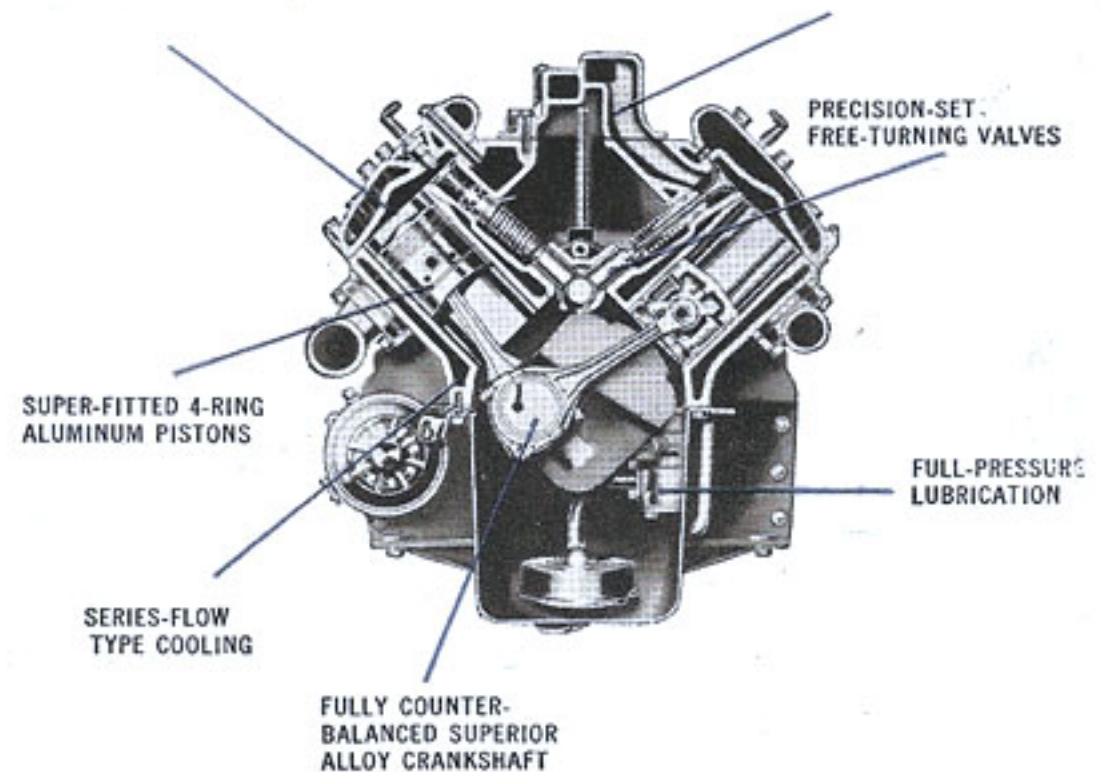



## 110-H.P. STRATO-STAR V-8

Here's a Ford Police Car engine with power aplenty! The famous Ford Strato-Star V-8 (right) has a mighty 7.2 to 1 compression ratio and a big 110 horsepower at 3800 rpm. It is second only to the "Interceptor" for police work. The sparkling performance of the Strato-Star V-8 results from its high-compression design and the high-lift valves which allow a greater volume of fuel mixture to enter the cylinders . . . and permit easier escape of the exhaust gases. Automatic Power Pilot is built in for fuel economy.

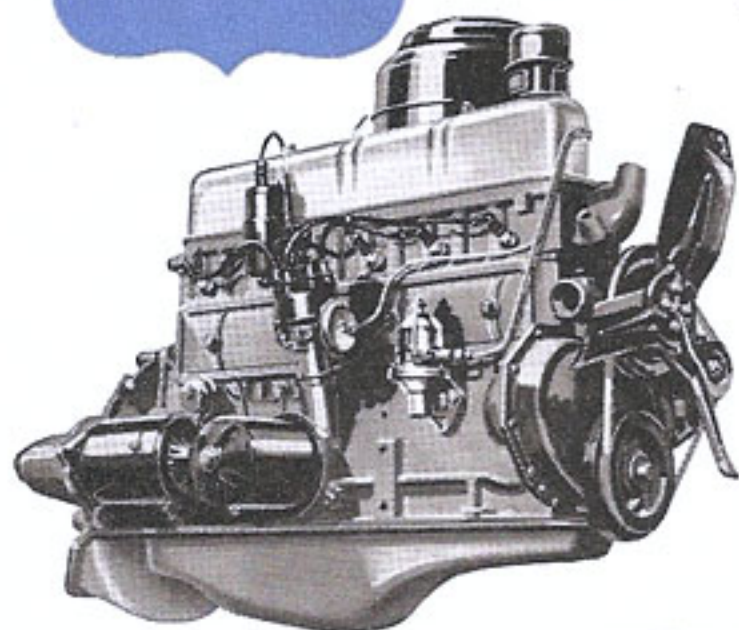
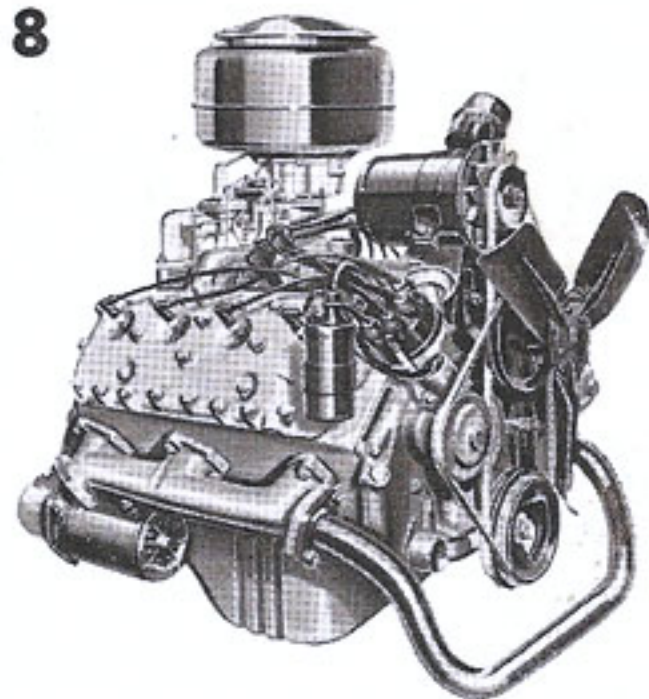

## 101-H.P. MILEAGE MAKER SIX

The completely modern Ford Mileage Maker Six (left) stresses economy combined with matchless performance. It outpaces every other Six in its class in fast, dependable six-cylinder power. Overhead rotating-type valves . . . high-compression, low-friction design . . . Ford's exclusive Automatic Power Pilot . . . all contribute, as a team, to the superb power output, high operating efficiency and the "gas-savingest" performance in the low-price field!

# FORD PRESENTS 41 "Worth More" FEATURES FOR '53

### 1. HULL-TIGHT BODY CONSTRUCTION

Ford Hull-Tight Body Construction seals out dust, noise, water and weather. Husky box-section structure for strength and longer life.



### 2. BIG, HUSKY CHASSIS WITH AUTOMATIC RIDE CONTROL

Both husky chassis and Automatic Ride Control contribute to the '53 Ford's new Miracle Ride which smooths out rough roads, adds to driver efficiency.

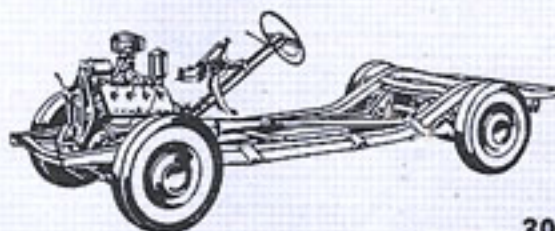

- 3. Trend-setting styling.
- 4. Baked enamel finish.
- 5. Presto-Lift counterbalanced hood.
- 6. Key-Release counterbalanced deck lid, Space Saver hinges.
- 7. Ford Quality Crestmark Body.
- 8. Advanced quality body insulation.
- 9. Color-keyed interior-exterior combinations.
- 10. Widest choice of models in the low-price field.
- 11. MagicAire Heating-Ventilating System.\*
- 12. Flight-Style control panel, individually lighted controls.

- 13. Full-Circle Visibility.
- 14. I-REST tinted safety glass.\*
- 15. Automatic Posture Control.
- 16. Foam rubber cushions, non-sag springs in seats.
- 17. Push-button door handles, rotor-type latches, weatherproof locks.
- 18. Silent-Doorman door checks, free-entree offset door hinges.
- 19. Center-Fill Fueling.
- 20. Wide front tread.
- 21. Tailored-to-weight front springs.

- 22. Variable-Rate Rear Spring Suspension.
- 23. Viscous Control Shock Absorbers.
- 24. K-bar frame, box-section side rails, 5 cross members.
- 25. Magic Action, Double-Seal Brakes.
- 26. Power-Pivot suspended foot pedals, dash-mounted brake master cylinder.
- 27. Free-action hand brake.
- 28. Power-Cushion semi-centrifugal clutch.
- 29. Balanced-ease steering.

- 30. Safety-Sequence Drive Selector.†
- 31. Fordomatic Drive.\*
- 32. Overdrive.\*
- 33. Only V-8 in low-price field.
- 34. Most modern Six in low-price field.
- 35. Automatic Power Pilot.
- 36. Free-turning, high-lift valves.
- 37. Super-fitted aluminum pistons.
- 38. Precision-molded, superior alloy crankshaft.
- 39. Precision-molded, high alloy exhaust valves.
- 40. Waterproof Ignition System.
- 41. Key-turn starting.

\*Optional at extra cost.

†Standard with Fordomatic.

**FORD...** *the new Standard of the American Road!*

# PUT MORE SAFETY, COMFORT AND ECONOMY

## INTO 24-HOUR SERVICE WITH THESE FACTORY-INSTALLED FORD OPTIONS!\*

\*AVAILABLE AT TRADITIONALLY LOW FORD PRICES

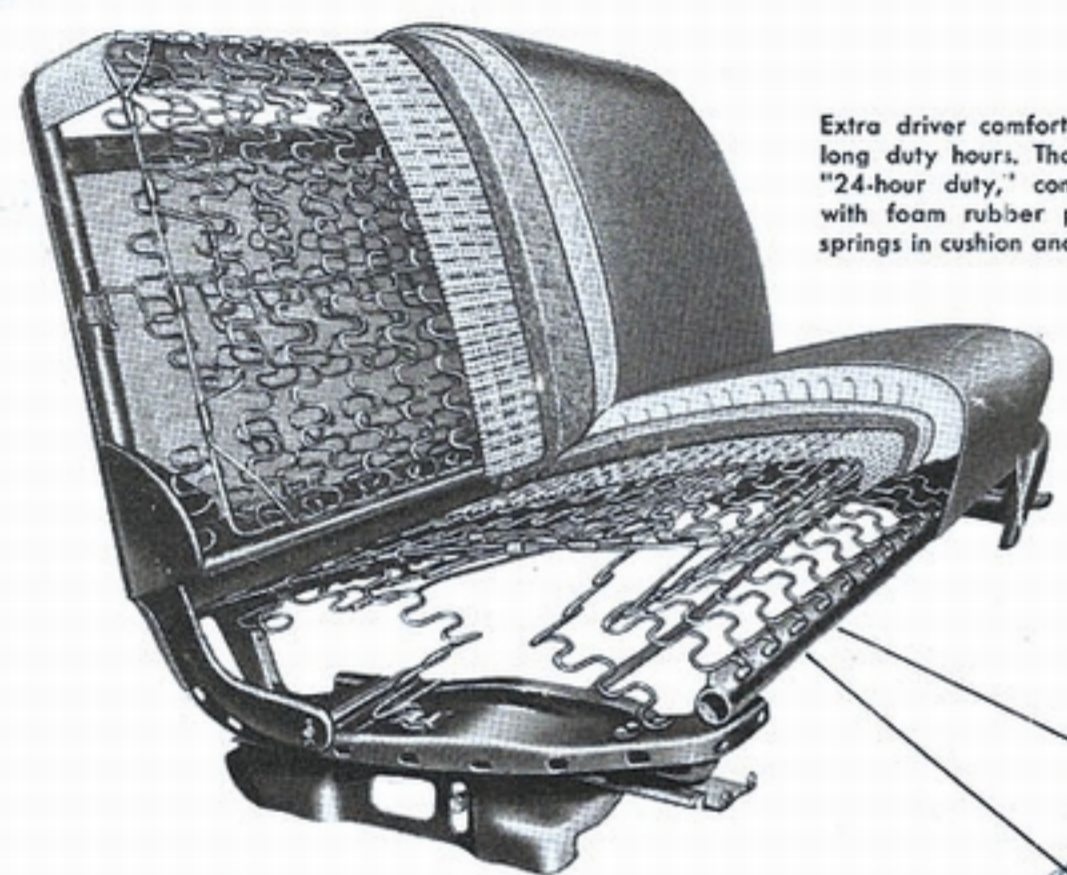

Extra driver comfort means less driver fatigue during long duty hours. That's why Ford offers these special "24-hour duty," contour-styled front and rear seats with foam rubber pads over heavy gage, non-sag springs in cushion and seat back.

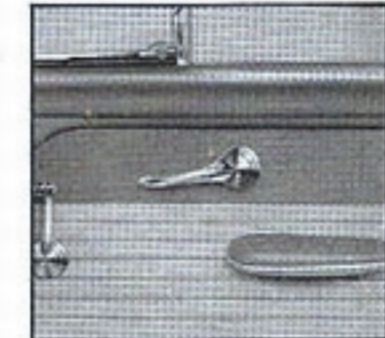

Extra sturdy door pull handles for front and rear doors last longer, function as arm rests.\* Available in standard or special trim.



Cozy warmth is provided by Mag Air Heating-Ventilating System (control panel shown), or by the recirculating type heater-defroster.

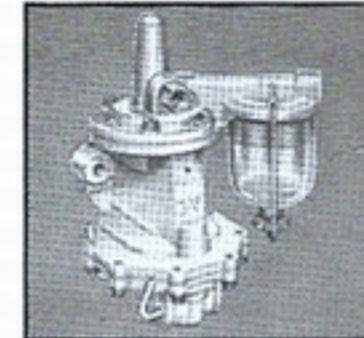

For positive windshield wiper operation, the combination fuel and vacuum booster pump is available. (Standard equipment with "Interceptor" V-8.)



An extra heavy duty generator—of 40, 45 or 60 amps. output—provides extra power. 80-, 60-, or 50-amp. alternator rectifier systems also available.

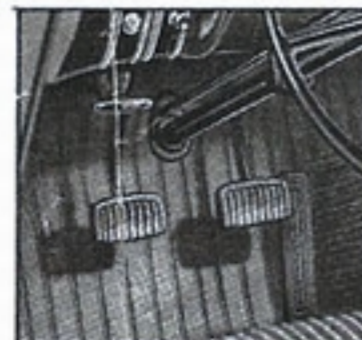
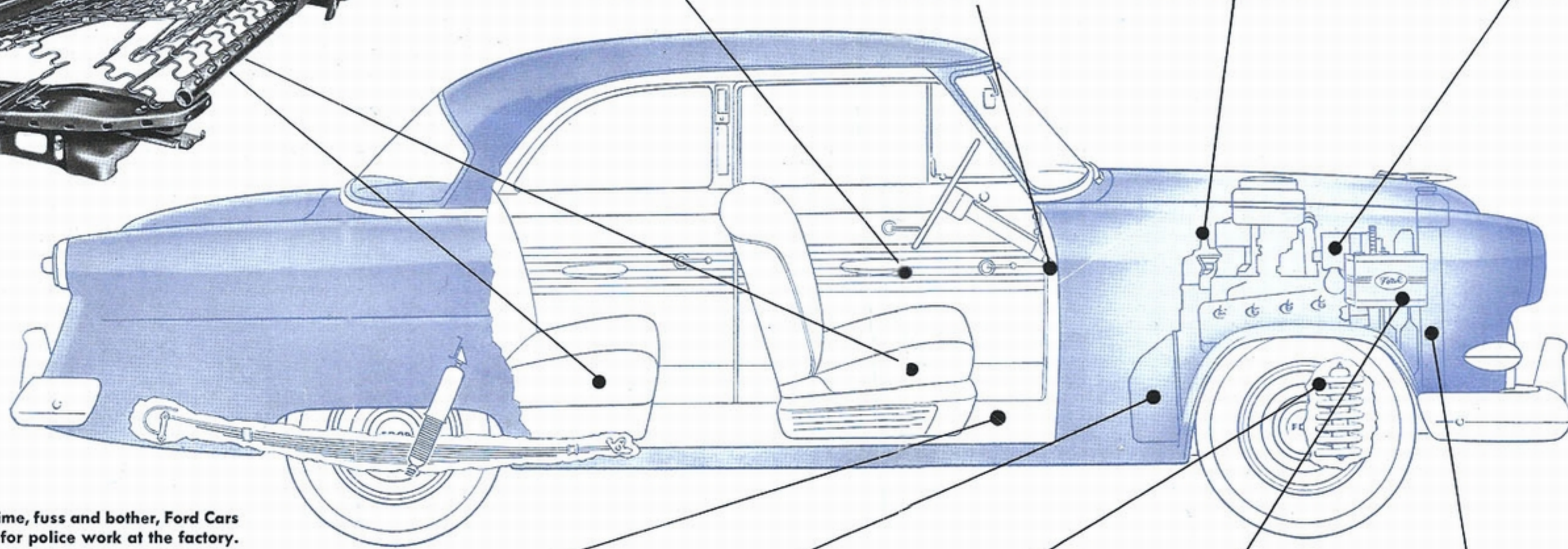

Exceptionally thick floor mats, front and rear, reinforce "wear points," last longer in rigorous police car service.



Heavy duty 10" clutch is the positive-action type, lasts longer. (Std. on "Interceptor" V-8 with Conventional Drive or Overdrive.)

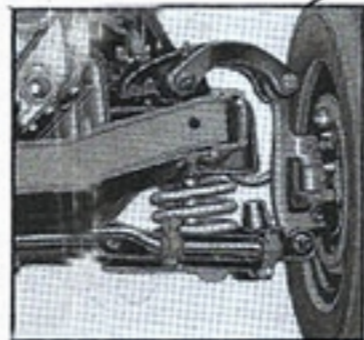

Heavy duty front and rear springs offer greater stability on the road. Heavy duty shock absorbers smooth out rough roads.



Extra heavy duty 120, 130 or 135 amp.-hrs. battery lasts longer, is more dependable under heavy loads.

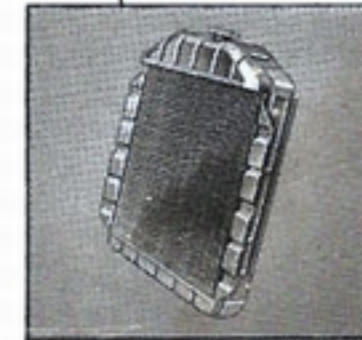

Sturdy, heavy duty radiator with a thick core improves engine cooling under all idling or operating conditions.

To save you time, fuss and bother, Ford Cars are equipped for police work at the factory. Merely specify what equipment you desire when you place your original new-car order. The "heavy duty" police car items illustrated here on a Customline Tudor Sedan will pay for their relatively low cost by giving longer service, reducing driver and rider fatigue, and lowering operating and maintenance costs to the minimum.

You also have a choice of three great Ford drives: Conventional or, at extra cost, Overdrive or Fordomatic Drive.

\*Standard in Customline, extra cost in Mainline.

### ORDER THESE OTHER IMPORTANT ACCESSORIES AND OPTIONS FOR YOUR FORD POLICE CAR THROUGH YOUR FORD DEALER

- ONE-QUART FIRE EXTINGUISHER
- SPOTLIGHT
- FULL TIRE CHAINS
- TURN INDICATOR\*
- BACK-UP LIGHTS\*
- WINDSHIELD WASHER\*
- GLARE-PROOF INSIDE REAR VIEW MIRROR
- OUTSIDE REAR VIEW MIRROR
- BUMPER GUARD
- ENGINE COMPARTMENT LIGHT
- COURTESY AND MAP LIGHT
- GLOVE COMPARTMENT LIGHT
- LUGGAGE COMPARTMENT LIGHT
- ELECTRIC CLOCK\*
- AUTOMATIC CIGAR LIGHTER
- I-REST TINTED SAFETY GLASS\*

\*Also Factory-Installed Options.

# FORD POLICE CAR SPECIFICATIONS

**125-H.P. V-8 INTERCEPTOR:** L-head, 90° V-type; 3.19 in. bore x 4 in. stroke; 255.4 cu. in. displacement; 7.2 to 1 compression ratio. Fully counter-balanced cast alloy crankshaft; selectively-fitted, steel-backed, thin shell main and crankpin bearings. Tin-plated, Super-Fitted aluminum-alloy pistons; 4 rings, top ring chrome plated, second ring cadmium plated. Precision-set free-turning valves. Full-Flow cooling system, 22-quart capacity (plus 1 qt. for heater); heavy-duty radiator core; extra capacity 5-bladed fan; pressure-type radiator cap; thermostatic capsule type thermostats. Dual downdraft, concentric-bowl carburetor with automatic choke and manifold heat control valve; dual exhaust system; diaphragm-type fuel pump with vacuum booster unit\* for positive windshield wiper operation; oil-bath type air cleaner.\* Full-pressure lubrication; by-pass type oil filter\* with replaceable element; positive crankcase ventilation; oil capacity (including filter) 5 qts. dry—4 qts. refill. Automatic Power Pilot; Waterproof Ignition System; 35-amp. generator; 3-unit regulator; high-torque starting motor; 17-plate, 90 amp. hr. battery.

**110-H.P. STRATO-STAR V-8:** L-head, 90° V-type; 3.19 in. bore x 3.75 stroke; 239.4 cu. in. displacement; 7.2 to 1 compression ratio. Precision-molded, superior alloy crankshaft; selectively-fitted steel-backed, thin shell main and crankpin bearings. Tin-plated, Super-Fitted aluminum-alloy pistons, 4 rings—top 2 cadmium-plated. Precision-set free-turning valves. Series-flow cooling system, 22-quart capacity (plus 1 qt. for heater); pressure-type radiator cap thermostatic-capsule type thermostats. Dual downdraft carburetor; manual choke; automatic heat control valve; diaphragm-type fuel pump; oil bath air cleaner.\* Full-pressure lubrication; by-pass oil filter\* with replaceable element; positive crankcase ventilation; oil capacity (including filter) 5 qts. dry—4 qts. refill. Automatic Power Pilot; Waterproof Ignition System; 35-amp. generator; 3-unit regulator; high-torque starting motor; 17-plate, 90 amp. hr. battery.

**101-H.P. MILEAGE MAKER SIX:** low-friction overhead valve, in-line type, 3.56 in. bore x 3.6 in. stroke; 215.3 cu. in. displacement; 7.0 to 1 compression ratio. Precision-molded, superior alloy crankshaft with vibration damper; selectively-fitted, steel-backed, thin shell main and crankpin bearings. Tin-plated, Super-Fitted aluminum alloy pistons, 3 rings—top 2 cadmium-plated. Adjustable, free-turning valves. Series-flow cooling system, 15-quart capacity (plus 1 qt. for heater); pressure-type radiator cap; thermostatic-capsule type thermostat. Unit-design downdraft carburetor; manual choke; automatic heat control valve; diaphragm type fuel pump; oil bath air cleaner.\* Full-pressure lubrication; full-flow type oil filter\* with replaceable element; positive crankcase ventilation; oil capacity (including filter), 5 qts. dry—4 qts. refill. Automatic Power Pilot; Waterproof Ignition System; 35-amp. generator; 3-unit regulator; high-torque starting motor; 17-plate, 90 amp. hr. battery.

†Combination fuel and vacuum pump, optional at extra cost, is factory-installed on all cars sold in states requiring positive action windshield wiper operation and on all cars equipped with Overdrive or Fordomatic drive.  
\*Equipment included at extra cost.

**CLUTCH** (with Conventional and Overdrive transmissions): 9½ in., dry, single plate, semi-centrif-

ugal type is standard with Strato-Star V-8 and Mileage Maker Six engines. Heavy duty 10" clutch is standard with V-8 Interceptor engine and available at extra cost on Strato-Star V-8 and Mileage Maker Six engines. Power-Pivot pedal and linkage.

**CONVENTIONAL DRIVE:** Selective gear type, 3 speeds forward, one reverse; all gears helical type; forged-bronze synchronizers for second and third speeds. Ratios: 1st—2.779 to 1, 2nd—1.614 to 1, 3rd—1.000 to 1, Reverse—3.635 to 1.

**OVERDRIVE** (optional at extra cost): 3 speed selective gear type transmission combined with planetary gear train which provides automatic fourth speed gear that cuts in at 27 mph (approx.) cuts out at 21 mph (approx.); ratio 0.70 to 1.

**FORDOMATIC DRIVE** (optional at extra cost): single-stage torque converter type with automatic planetary gear train; forced air cooling; 5 position, Safety-Sequence Drive Selector.

**DOUBLE-DROP FRAME:** 5 cross members and heavy box-section side rails; K-bar construction.

**INDEPENDENT FRONT WHEEL SUSPENSION:** swing-link type with Hydra-Coil springs; tubular double-acting Viscous Control shock absorbers; one-piece rubber-mounted stabilizer. Heavy duty springs and extra capacity shock absorbers at extra cost.

**VARIABLE-RATE REAR SPRING SUSPENSION:** long 7-leaf, semi-elliptic springs, longitudinally mounted; rubber bushings at shackles and brackets; impregnated inserts between tips of upper leaves; tension type shackles; tubular, double-acting diagonally mounted, Viscous Control shock absorbers. Heavy duty 7-leaf rear springs and extra capacity shock absorbers at extra cost.

**REAR AXLE:** semi-floating type; hypoid gears; forged axle shafts with integral flanges. Ratios: with Conventional Drive, 3.90 to 1 std., 4.10 to 1 optional; with Overdrive, 4.10 to 1 std., 3.90 to 1 optional; with Fordomatic, 3.31 to 1 std., 3.54 to 1 optional.

**DOUBLE-SEAL HYDRAULIC BRAKES:** Power-Pivot pedal actuation of 4-wheel duo-servo type brakes; 10" composite steel and cast iron drums; 173.5 sq. in. molded lining area. Hand brake is T-handle on dash actuating brakes. Heavy duty brakes with extra long-wearing lining available at extra cost.

**SYMMETRICAL STEERING LINKAGE:** steering has spring-loaded ball-stud in steering cross link; worm and roller steering gear with triple-tooth roller on needle-bearing; 18.2 to 1 gear ratio; 26.3 to 1 over-all steering ratio; 18 in. diameter steering wheel. Turning diameter (center of outer front wheel) approx. 40 feet.

**WHEELS AND TIRES:** 6.70 x 15 4-ply tires on 5" rims standard on Mainline and Customline Sedans. Black sidewalls standard, white sidewalls optional at extra cost. 6.70 x 15 6-ply tires also available at extra cost.

**EXTERIOR DIMENSIONS:** 115" wheelbase; 58" front and 56" rear treads; 73.2" over-all width of Mainline Sedans, 74.3" over-all width of Customline Sedans; 197.8" over-all length; 62.3" over-all height with normal load.

**INTERIOR DIMENSIONS:** front seat—42.8" leg room (seat in rearmost position—4.1" total adjustment), 58.9" hip room, 55.2" shoulder room, 35.4" head room; rear seat—41.5" leg room (to integral foot rest), 58.9" hip room, 55" shoulder room (Tudor Sedans), 34.2" head room.

**INSTRUMENTS AND CONTROLS:** Flight-Style Control Panel with illuminated bezels around 4-position starter-ignition switch and around control knobs for windshield wipers, main light switch, ventilating air ducts, interior light switch, cigarette lighter (except Mainline) and choke control (except Interceptor V-8). Indirectly illuminated instrument cluster has oil pressure, fuel level, water temperature and battery charge indicators grouped around semicircle speedometer dial with odometer located at center. Control Panel illumination intensity controlled by rheostat. T-handle for parking brake on lower left edge of panel; head lamp beam control switch on toe board; finger-tip gearshift lever; hood latch and safety catch operated from front by separate levers.

**MAINLINE STANDARD EQUIPMENT:** sun visor on driver's side, two-spoke black rubber steering wheel with horn button at center; ash tray and locking type parcel compartment in instrument panel; dual windshield wipers; twin horns; rear view mirror on windshield upper molding; interior light on left center pillar operated by manual switch on instrument panel. Contour-type seats with pillow backs, non-sag construction with foam rubber pad in cushions; Automatic Posture Control front seat mechanism. Gray and Gold Stripe Craftcord upholstery material, black rubber mats, front and rear; coat hooks; integral foot rest in rear compartment. Rain shields at front vent windows; black rubber exterior reveal molding at windshield and rear window; bright metal shield over lower part of body side embossments. Center-fill fuel tank in rear, capacity 17 gallons (U.S.). Optional at extra cost: Customline type arm rest(s), horn ring, two sun visors, cigarette lighter, stem-wind clock.

**CUSTOMLINE STANDARD EQUIPMENT** (in addition to or in place of Mainline items): two sun visors; horn ring; interior light on each center pillar operated by automatic front door switches in addition to manual control; cigarette lighter; stem-wind clock. Choice of Green and White Diagonal Craftweave, Two-Tone Gray Stripe Craftcord, or Two-Tone Tan Check Craftweave upholstery material; black rubber mat in front and pebble-grain rubber mat in rear in colors to harmonize with interior trim; assist loops in Tudor, robe cord in Fordor; arm rests, front and rear; one ash tray in rear compartment of Fordor, two in Tudor. Bright metal exterior reveal molding at windshield and rear window; bright metal body speedline molding with spear ornament; bright metal cap moldings on side embossments, with speedline moldings.

**OPTIONAL EQUIPMENT** (extra cost items in addition to those listed above): 80-, 60- or 50-amp. alternator rectifier system; heavy duty front and rear seats with extra heavy springs in cushions and seat backs; brown or green vinyl upholstery and interior trim; heavy duty front and rear floor mats; rear door pull cord; electric clock; heavy duty 40-amp. generator and regulator; 60-amp. generator with either 45-amp. or 60-amp. regulator; heavy duty batteries; heavy duty radiator core and extra capacity fan (Strato-Star V-8 and Mileage Maker Six).

*Equipment, accessories and trim subject to change without notice. The specifications contained herein were in effect at the time this folder was approved for printing. The Ford Division of the Ford Motor Company, whose policy is one of continuous improvement, reserves the right, however, to discontinue models at any time, or change specifications, design, or prices without notice and without incurring obligation.*

FORD Division of FORD MOTOR COMPANY

